

Cryogenic Service Valves



Valve Specialists™



Gate, Globe & Ball

ISO 9001



since 1990

CATALOG
C-CR01



INNOVATION



Simone Brevi and Roberto Brevi
Managing Director Founder & President



1998 was the year OMB_{spa} celebrated it's 25th Anniversary Over the years we have worked to create a company with an outstanding record

of innovation and improvement. We are now a market leader and to maintain this position and OMB's future development, it is our policy to embark upon a rigorous product development programme.

TRADITION

In the spirit of commitment to innovation it is my pleasure to introduce the renewed line of OMB products for critical cryogenic service: a complete range of forged steel gate, globe and ball valves designed to satisfy the most severe applications with innovative solutions and improved design.

Introduction	1
A Definition of cryogenic service	2
Design & Features	3
Quality & Test	4
Data Sheet	6
Materials	7
Gate Valves	8
Globe Valves	10
Check Valves	12
Ball Valves	12

OMB s.p.a. Plant in Cenate (Italy)





A HISTORY OF APPLICATIONS AND INNOVATIONS IN THE CRYOGENIC SERVICE FIELD

OMB cryogenic gate and globe valves have been developed to satisfy the industry needs for a reliable and durable product.

In the past 25 years OMB supplied several projects all over the world achieving an outstanding record of installations, with high level of satisfaction from all our customers.

The continuous effort to improve our products and our service led to the development of a new range of cryogenic valves which includes the latest technical

advancements and has been tested through the most innovative test rigs simulating the actual working condition of the valve in the plants.

In the following pages you will find the most relevant answer to your needs in controlling gas and fluids at high pressure and low temperature.

At OMB we are ready to answer all your question regarding these or any other valve because we truly are *italics your* 'valves specialist'.

EXPERIENCE

A DEFINITION OF CRYOGENIC SERVICE

'Cryogenic Service' refers to service condition where temperatures are significantly below normal atmospheric temperatures. Definitions vary, but often any temperature below -50°F / -45°C is considered cryogenic. The bonnet of gate and globe valves is of the extended type with sufficient length and a vapour space between body and stuffing box in order to maintain the gland packing sufficiently near ambient temperature to prevent icing of the top works and keep the packing soft and pliable for optimum sealing characteristics.

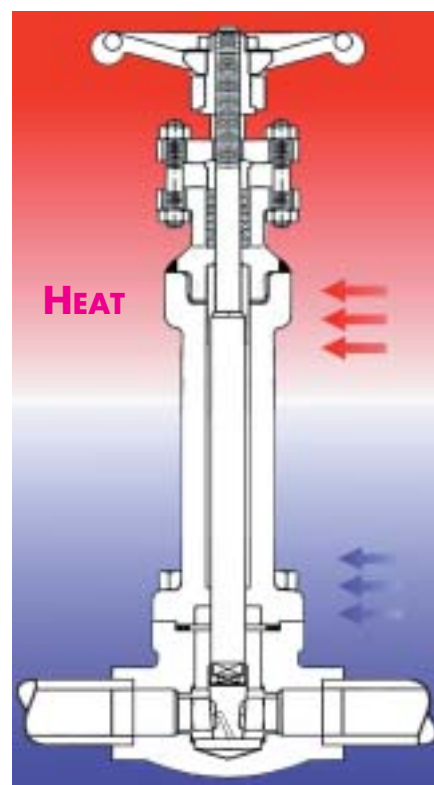

CRYOGENIC SOCIETY
OF AMERICA INC.



CORPORATE SUSTAINING MEMBER

OMB and OMB's Logo are registered marks of OMB spa. All other brands and product names are trade marks or registered marks of their respective companies.

ENGINEERING

For liquid service where boil off or vaporization might be a problem (which is usually the case), OMB propose a solution for venting boiled-off gases to prevent overpressuring damage. Vent holes are provided in gate

valve wedges (as seen on the side) with a clear marking on the outside of the valve. The use of globe valves that are inherently free from trapped volumes are as well a common solution.

VENT HOLE AVAILABLE ON GATE VALVES

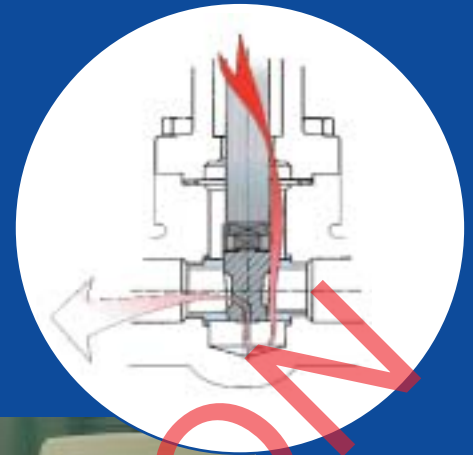

INNOVATION

STANDARD DESIGN & FEATURES OF CRYOGENIC SERVICE VALVES

In the following pages you will find some of OMB's solution to the 'cryogenic service' problem with a listing of the type of gate, globe and ball valves engineered by OMB for typical cryogenic applications.

As shown above, the gate valves feature a pressure release device to prevent the pressure increase following thermal expansion of gases trapped in the upper stem chamber.

Both gate and globe valve extensions are made in one single piece of forged steel material,

thus improving the strength of the complete valve.

Four bolts connect the body to the extension in the lower pressure range (up to the Class 800) while higher pressure valves have the body connected to the extension with 6 or 8 bolts. This design allows an easy disassembly of the extension/bonnet part to inspect the seats and wedge/disc area and, if needed, maintenance.

Custom design and modified materials are available to special request.





OMB has achieved a superior reputation as a high quality manufacturer.

Starting in the mid '70s, a fully implemented Q.A. programme has improved the level of service and the overall products quality.

In 1990 this system was first certified according ISO 9001 standards. Engineering, manufacturing, assembly and testing is therefore submitted to close quality monitoring procedures.

Cryogenic service valves components are submitted to a stringent evaluation procedure for their critical application.

A team of skilled and experienced personnel assemble the cryogenic products.

Thorough testing and inspection of all product components ensure the integrity and reliability of OMB cryogenic valves.

The in-house laboratory use the latest technologies in control equipment as well as custom designed machines and test rigs. The capability of performing all the relevant tests in house guarantees a higher level of control and cost efficiency.

At each stage in the development procedure the aim of OMB's engineering team is to design a valve combining the best performance at the lowest manufacturing and operating cost.

For this reason OMB's cryogenic service valves achieved outstanding

QUALITY

results in all the markets gaining OMB a reputation as reliable and efficient supplier.

To improve even further in the past 3 years OMB increased its presence abroad with a number of branch offices and service centers where skilled valve specialists are cooperating with the customers in developing new product and servicing various types of applications: Houston, TX and Providence, RI (USA), Montreal (Canada), Madrid (Spain) and Singapore.

Adding to this the exacting standards of quality achieved throughout the manufacturing process, and it becomes apparent why OMB cryogenic service valves represent such outstanding value.

**ECO-L-SEAL™
GUARANTEES
500 PPM**

OMB introduces newly developed cryogenic valve packing and valve design which provide **low-emission service**

to meet the most stringent standards and tests procedures.

OMB new **ECO-L-SEAL™** packing provide the safest and most economical solution to fugitive emission control in cryogenic service.

ISO 9001



Certified since 1990

Low Temperature

Test

PURPOSE

The purpose of such tests are to demonstrate the acceptable performance of OMB cryogenic valves at specific low temperatures.

AMBIENT

Gate, globe and ball valves up to 2" (DN 50 mm) are tested at cryogenic temperatures (down to -512°F / -196°C) where test temperature is achieved in a specially constructed tank with a purge mixture of nitrogen and helium gas (99% +1%).

PROCEDURE

After a full hydrostatic and pneumatic API 598 test the valve is disassembled cleaned and dried.

After reaching test temperature the valve is tested for:

- operability
- torque
- seat (via flowmeter)
- packing and gasket (via sniffer)

CERTIFICATION

Test report are filled by QA Manager with a serial number and issued with OMB test certs.

OMB valves subjected to cryogenic tests are designed a tested to:

- BS 6364
- API 598/ BS 6755 part 1
- ASME B16.34
- Spe 77/306
- ES /189
- UNI EN ISO 9001
- Clients' Specifications

RELIABILITY



testing facilities

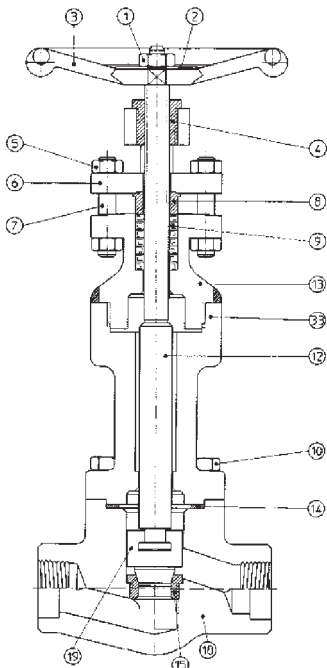

GLOBE STANDARD MATERIALS SPECIFICATION

DESCRIPTION	LF2/410	F304/304	F316/316	F51/F51
1 Wheelnut	Carbon Steel	Carbon steel	Carbon steel	Stainless steel
2 Nameplate	Aluminium	Aluminium	Aluminium	Aluminium
3 Handwheel	Carbon steel	Carbon steel	Carbon steel	Carbon steel
4 Yoke Nut	416	416	416	416
5 Gland Nut	Gr.8	Gr.8	Gr.8	Gr.8
6 Gland Flange	LF2	F304	F316	F51
7 Gland Stud	B8	B8	B8	B8
8 Gland	410	304	316	316
9 Packing	PTFE	PTFE	PTFE	PTFE
10 Bolts	L7	B8	B8	B8
12 Stem	410	304	316	F51
13 Bonnet	LF2	F304	F316	F51
14 Gasket	18/8 + PTFE spiral wound			
15 Seat	410	304	316	F51
18 Body	LF2	F304	F316	F51
33 Extension	LF2	F304	F316	F51
19 Disc	410	304	316	F51

DRAFT

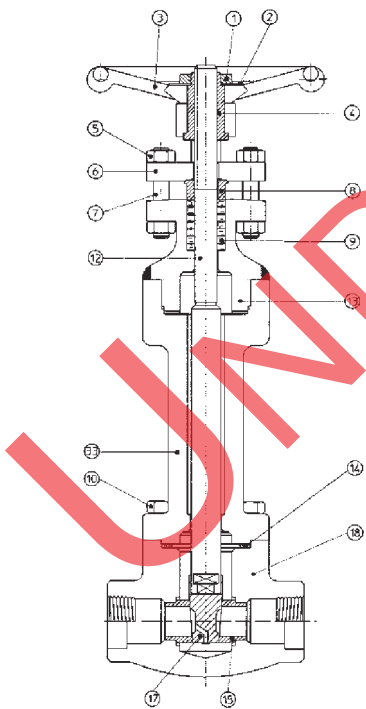

GATE STANDARD MATERIALS SPECIFICATION

DESCRIPTION	LF2/410	F304/304	F316/316	F51/F51
1 Wheelnut	Carbon steel	Carbon steel	Carbon steel	Stainless steel
2 Nameplate	Aluminium	Aluminium	Aluminium	Aluminium
3 Handwheel	Carbon steel	Carbon steel	Carbon steel	Carbon steel
4 Yoke Nut	416	416	416	416
5 Gland Nut	Gr.8	Gr.8	Gr.8	Gr.8
6 Gland Flange	LF2	F304	F316	F51
7 Gland Stud	B8	B8	B8	B8
8 Gland	410	304	316	316
9 Packing	PTFE	PTFE	PTFE	PTFE
10 Bolts	L7	B8	B8	B8
12 Stem	410	304	316	F51
13 Bonnet	LF2	F304	F316	F51
14 Gasket	18/8 + PTFE spiral wound			
15 Seat	410	304	316	F51
18 Body	LF2	F304	F316	F51
33 Extension	LF2	F304	F316	F51
17 Wedge	410	304	316	F51

OMB valves are manufactured in a wide range of materials, supplied by the best available steel mills, formed by well known forge master with outstanding equipment and experience. All the material can be certified for chemical composition and mechanical properties.

CHEMICAL COMPOSITION										
BODY AND BONNET MATERIALS										
ASTM Material	C %	Mn %	P %	S %	Si %	NI %	Cr %	Mo %	Co %	Other
ASTM A350 LF2	0.22	0.60 1.35	0.035	0.040	0.15 0.30	0.40 max	0.30 max	0.12 max	-	Cu 0.40 max Nb 0.02 max V 0.05 max
ASTM 182 F304	0.08 max	2.0 max	0.045	0.030	1.00 max	8.00 11.00	18.00 20.00	-	-	N. 0.10 max
ASTM 182 F316	0.08 max	2.0 max	0.045	0.030	1.00 max	10.00 14.00	16.00 18.00	2.00 3.00	-	N. 0.10 max
ASTM 182 F51	0.030 max	2.0 max	0.030	0.020	1.00 max	4.50 6.50	21.00 23.00	2.50 3.50	-	N. 0.08 N. 0.20

CHEMICAL COMPOSITION										
TRIM MATERIALS & BOLTING MATERIALS										
ASTM Material	C %	Mn %	P %	S %	Si %	NI %	Cr %	Mo %	Co %	Other
ASTM A276 Type 410	0.15 max	1.00 max	0.040	0.030	1.00 max	-	11.50 13.50	-	-	-
ASTM A479 Type 304	0.08 max	2.00 max	0.045 max	0.030 max	1.00 max	8.00 10.50	18.00 20.00	-	-	N. 0.10 max
ASTM A479 Type 316	0.08 max	2.00 max	0.045 max	0.030 max	1.00 max	10.00 14.00	16.00 18.00	2.00 3.00	-	N. 0.10 max
STELLITE Gr. 6	1.00	1.00 max	-	-	1.00	3.0 max	28.00	-	-	Fe: 3.0 max W: 4.0 - CO: Bal.
ASTM A193 B7	0.37 0.49	0.65 1.10	0.035 max	0.04 max	0.15 0.35	-	0.75 1.20	0.15 0.25	-	-
ASTM A193 B8	0.08 max	2.00 max	0.045 max	0.030 max	1.00 max	8.00 10.50	18.00 20.00	-	-	-
ASTM A194 2H	0.40 min	1.00 max	0.040 max	0.050 max	0.40 max	-	-	-	-	-
ASTM A194 Gr 8	0.08 max	2.00 max	0.045 max	0.030 max	1.00 max	8.00 10.5	18.00 20.00	-	-	-

Note: these charts are for reference only. OMB recommends customer engineers to analyse service requirements and specify the materials they consider optimum. OMB cannot be held liable for any damage resulting from the use of the tables.

MATERIAL TEST , INSPECTION AND CERTIFICATION

Upon receiving forgings OMB QC department inspect each lot in the laboratory to test material conformity with the standards and with the customer specifications. Each valve is then supplied with mill test certificate (according to DIN 31B) proving the material origin and quality.

SPECIAL MATERIALS

Special grades of LF1, LF2, LF3, F347, F321, F53 and F44 have been selected and used for cryogenic applications: OMB has a long experience in supplying customer specified material grades.



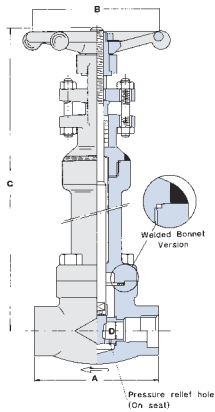

RATINGS: A182 - F304 - 1920 p.s.i. @ 100°F

CLASS 800

BOLTED BONNET - REGULAR AND FULL PORT - API 602 - BS 5352
Outside Screw & Yoke - Threaded and Socket Weld Ends

REGULAR PORT	CR-810	-	1/2	3/4	1	1.1/4	1.1/2	2	-						
FULL PORT	CR-610	1/4	3/8	1/2	3/4	1	1.1/4	1.1/2	2						
		mm	in.	mm	in.	mm	in.	mm	in.	mm	in.	mm	in.	mm	in.
End to End	A	80	3.14	80	3.14	90	3.54	110	4.33	127	5.00	127	5.00	150	5.90
Handwheel	B	90	3.54	90	3.54	90	3.54	110	4.33	130	5.11	130	5.11	180	7.08
Center to Top Open	C	398	15.7	398	15.7	413	16.2	428	16.8	460	18.1	493	19.4	512	20.1
Dia. of Port	D	8	0.31	10	0.39	14	0.55	19	0.75	24	0.94	30	1.18	37	1.45
Approx. Weight	Kg / Lb	3.2	7.0	3.2	7.0	4.1	9.0	6.4	14.0	10.5	23.1	12	26.4	14.8	32.6

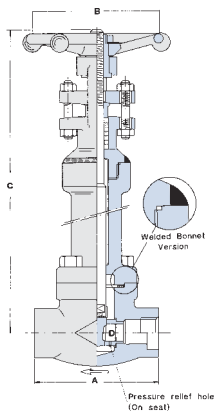

RATINGS: A182 - F304 - 3600 p.s.i. @ 100°F

CLASS 1500

BOLTED BONNET - REGULAR AND FULL PORT - API 602 - BS 5352
Outside Screw & Yoke - Threaded and Socket Weld Ends

REGULAR PORT	CR-R910	-	1/2	3/4	1	1.1/4	1.1/2	2	-						
FULL PORT	CR-910	1/4	3/8	1/2	3/4	1	1.1/4	1.1/2	2						
		mm	in.	mm	in.	mm	in.	mm	in.	mm	in.	mm	in.	mm	in.
End to End	A	90	3.54	90	3.54	110	4.33	127	5.00	127	5.00	127	5.00	150	5.90
Handwheel	B	90	3.54	90	3.54	110	4.33	110	4.33	130	5.11	130	5.11	180	7.08
Center to Top Open	C	396	15.6	396	15.6	430	16.9	465	18.3	485	19.1	514	20.2	565	22.2
Dia. of Port	D	8	0.31	10	0.39	14	0.55	19	0.75	24	0.94	30	1.18	37	1.45
Approx. Weight	Kg / Lb	4.1	9.0	4.1	9.0	6.7	14.7	11	24.2	12.3	27.1	15.8	34.8	30	66.0

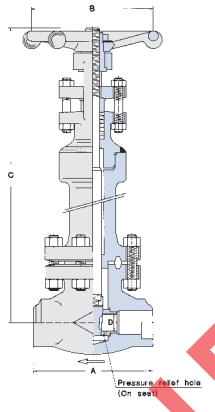

RATINGS: A182 - F304 - 3600 p.s.i. @ 100°F

CLASS 1500

ROUND BOLTED BONNET RJ - FULL PORT - BS 5352
Outside Screw & Yoke - Threaded and Socket Weld Ends

FULL PORT	CR-RJ910	1/4	3/8	1/2	3/4	1	1.1/4	1.1/2	2						
		mm	in.	mm	in.	mm	in.	mm	in.	mm	in.	mm	in.	mm	in.
End to End	A	-	-	-	-	110	4.33	150	5.90	150	5.90	-	-	210	8.26
Handwheel	B	-	-	-	-	110	4.33	130	5.11	250	9.84	-	-	300	11.8
Center to Top Open	C	-	-	-	-	450	17.7	510	20.0	522	20.5	-	-	585	23.0
Dia. of Port	D	-	-	-	-	14	0.55	19	0.75	24	0.94	-	-	37	1.45
Approx. Weight	Kg / Lb	-	-	-	-	7.8	17.1	15.5	34.1	17	37.4	-	-	34	74.9

Spiral wound gasket joint available on request.

Ring-Joint gasket according to ANSI B16.20 - API 6A.

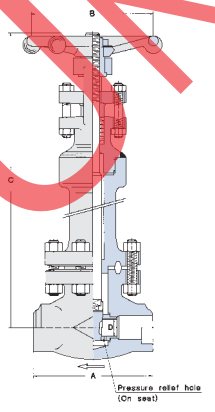

RATINGS: A182 - F304 - 6000 p.s.i. @ 100°F

CLASS 2500

ROUND BOLTED BONNET RJ - FULL PORT - BS16.34
Outside Screw & Yoke - Socket and Butt Weld Ends

FULL PORT	CR-RJ2510	1/4	3/8	1/2	3/4	1	1.1/4	1.1/2	2						
		mm	in.	mm	in.	mm	in.	mm	in.	mm	in.	mm	in.	mm	in.
End to End	A	-	-	-	-	150	5.90	150	5.90	210	8.26	-	-	235	9.25
Handwheel	B	-	-	-	-	130	5.11	130	5.11	250	9.84	-	-	300	11.8
Center to Top Open	C	-	-	-	-	500	19.6	513	20.2	548	21.5	-	-	680	26.7
Dia. of Port	D	-	-	-	-	14	0.55	19	0.75	24	0.94	-	-	37	1.45
Approx. Weight	Kg / Lb	-	-	-	-	15.5	34.1	15.8	34.8	34.4	75.7	-	-	50	110.1

Ring-Joint gasket according to ANSI B16.20 - API 6A.

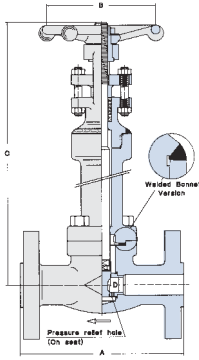

RATINGS: A182 - F304
 Class 150 - 275 p.s.i. @ 100°F
 Class 300 - 720 p.s.i. @ 100°F
 Class 600 - 1440 p.s.i. @ 100°F

CLASS 150-300-600

BOLTED BONNET - REGULAR PORT - API 602 - BS 5352
 Outside Screw & Yoke - Integral Flanged Ends according to ANSI B16.5

REGULAR PORT		1/4		3/8		1/2		3/4		1		1.1/4		1.1/2		2	
		mm	in.	mm	in.	mm	in.	mm	in.	mm	in.	mm	in.	mm	in.	mm	in.
Class 150	CR-F1-810	A	-	-	-	108	4.25	118	4.64	127	5.00	-	-	165	6.49	178	7.00
Class 300	CR-F3-810	A	-	-	-	140	5.51	153	6.02	165	6.49	-	-	191	7.51	216	8.50
Class 600	CR-F6-810	A	-	-	-	165	6.49	191	7.51	216	8.50	-	-	241	9.48	292	11.5
Handwheel		B	-	-	-	90	3.54	90	3.54	110	4.33	-	-	130	5.11	180	7.08
Center to Top Open	Class 150/300	C	-	-	-	420	16.5	445	17.5	453	17.8	-	-	493	19.4	512	20.1
	Class 600	C	-	-	-	398	15.7	413	16.2	428	16.8	-	-	493	19.4	512	20.1
Dia. of Port		D	-	-	-	10	0.39	14	0.55	19	0.75	-	-	30	1.18	37	1.45
Approx. Weight	Class 150	Kg / Lb	-	-	-	4.8	10.5	5.6	12.3	8.5	18.7	-	-	15	33.0	20.3	44.7
	Class 300	Kg / Lb	-	-	-	5.5	12.1	7	15.4	9.3	20.5	-	-	16.5	36.3	22.3	49.1
	Class 600	Kg / Lb	-	-	-	5.7	12.5	7	15.4	9.8	21.6	-	-	19.5	42.9	24.8	54.6

End to End dimensions according to ANSI B16.10

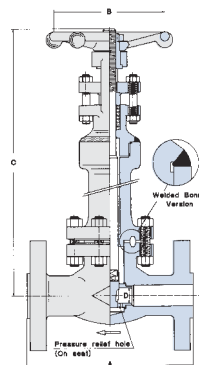

RATINGS: A182 - F304
 Class 150 - 275 p.s.i. @ 100°F
 Class 300 - 720 p.s.i. @ 100°F
 Class 600 - 1440 p.s.i. @ 100°F

CLASS 150-300-600

ROUND BOLTED BONNET - FULL PORT - BS 5352
 Outside Screw & Yoke - Integral Flanged Ends according to ANSI B16.5

FULL PORT		1/4		3/8		1/2		3/4		1		1.1/4		1.1/2		2	
		mm	in.	mm	in.	mm	in.	mm	in.	mm	in.	mm	in.	mm	in.	mm	in.
Class 150	CR-1-610	A	-	-	-	108	4.25	118	4.64	127	5.00	-	-	165	6.49	178	7.00
Class 300	CR-3-610	A	-	-	-	140	5.51	153	6.02	165	6.49	-	-	191	7.51	216	8.50
Class 600	CR-F6-RJ610	A	-	-	-	165	6.49	191	7.51	216	8.50	-	-	241	9.48	292	11.5
Handwheel		B	-	-	-	110	4.33	110	4.33	130	5.11	-	-	250	9.84	250	9.84
Center to Top Open		C	-	-	-	438	17.2	472	18.5	505	19.8	-	-	558	21.9	597	23.5
Dia. of Port		D	-	-	-	14	0.55	19	0.75	24	0.94	-	-	37	1.45	48	1.89
Approx. Weight	Class 150	Kg / Lb	-	-	-	8.1	17.8	14.3	31.5	17.5	38.5	-	-	37.8	83.2	40.3	88.7
	Class 300	Kg / Lb	-	-	-	8.3	18.2	14.5	31.9	17.9	39.4	-	-	38	83.7	40.5	89.2
	Class 600	Kg / Lb	-	-	-	8.8	19.3	15	33.0	18.5	40.7	-	-	39	85.9	42	92.5

End to End dimensions according to ANSI B16.10

Ring-Joint gasket according to ANSI B16.10 - API 6A

Spiral wound gasket joint and Welded Flanges for #150 - #300

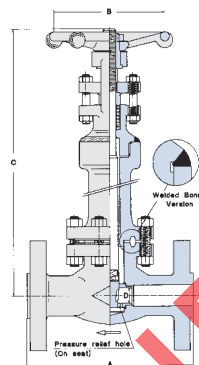

RATINGS: A182 - F304 - 3600 p.s.i. @ 100°F

CLASS 1500

ROUND BOLTED BONNET RJ - FULL PORT - BS 5352
 Outside Screw & Yoke - Integral Flanged Ends according to ANSI B16.5

FULL PORT		CR-F9-RJ910		1/4		3/8		1/2		3/4		1		1.1/4		1.1/2		2	
		mm	in.	mm	in.	mm	in.	mm	in.	mm	in.	mm	in.	mm	in.	mm	in.	mm	in.
End to End		A	-	-	-	216	8.50	229	9.01	254	10.0	-	-	305	12.0	368	14.5		
Handwheel		B	-	-	-	110	4.33	130	5.11	250	9.84	-	-	300	11.8	300	11.8		
Center to Top Open		C	-	-	-	475	18.7	510	20.0	537	21.1	-	-	595	23.4	643	25.3		
Dia. of Port		D	-	-	-	14	0.55	19	0.75	24	0.94	-	-	37	1.45	48	1.89		
Approx. Weight		Kg / Lb	-	-	-	13.8	30.4	21.5	47.3	24.5	53.9	-	-	47	103.5	71	156.3		

End to End dimensions according to ANSI B16.10

Ring-Joint gasket according to ANSI B16.20 - API 6A

Spiral wound gasket joint available on request

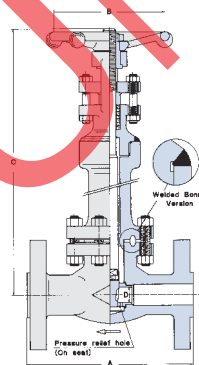

RATINGS: A182 - F304 - 6000 p.s.i. @ 100°F

CLASS 2500

ROUND BOLTED BONNET RJ - FULL PORT - BS16.34
 Outside Screw & Yoke - Integral Flanged Ends according to ANSI B16.5

FULL PORT		CR-F25-RJ2510		1/4		3/8		1/2		3/4		1		1.1/4		1.1/2		2	
		mm	in.	mm	in.	mm	in.	mm	in.	mm	in.	mm	in.	mm	in.	mm	in.	mm	in.
End to End		A	-	-	-	264	10.4	273	10.7	308	12.1	-	-	384	15.1	451	17.7		
Handwheel		B	-	-	-	130	5.11	130	5.11	250	9.84	-	-	300	11.8	300	11.8		
Center to Top Open		C	-	-	-	515	20.2	528	20.7	558	21.9	-	-	716	28.1	783	30.8		
Dia. of Port		D	-	-	-	14	0.55	19	0.75	24	0.94	-	-	37	1.45	37	1.45		
Approx. Weight		Kg / Lb	-	-	-	24.5	53.9	26.5	58.3	52	114.5	-	-	76	162.9	104	229.0		

End to End dimensions according to ANSI B16.10

Ring-Joint gasket according to ANSI B16.20 - API 6A.

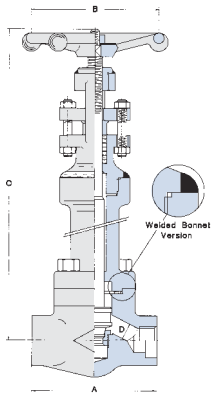

RATINGS: A182 - F304 - 1920 p.s.i. @ 100°F

CLASS 800 BOLTED BONNET - REGULAR AND FULL PORT - BS 5352

Outside Screw & Yoke - Threaded and Socket Weld Ends

REGULAR PORT	CR-830	-	1/2	3/4	1	1.1/4	1.1/2	2	-								
FULL PORT	CR-630	1/4	3/8	1/2	3/4	1	1.1/4	1.1/2	2								
		mm	in.	mm	in.	mm	in.	mm	in.	mm	in.	mm	in.	mm	in.		
End to End	A	80	3.14	80	3.14	90	3.54	110	4.33	127	5.00	155	6.10	170	6.69	210	8.26
Handwheel	B	70	2.75	90	3.54	90	3.54	110	4.33	130	5.11	130	5.11	180	7.08	180	7.08
Center to Top Open	C	398	15.7	398	15.7	415	16.3	430	16.9	463	18.2	498	19.6	507	20.0	567	22.3
Dia. of Port	D	7	0.28	9	0.35	13	0.51	17.5	0.69	22.5	0.89	29.5	1.16	35	1.37	45.5	1.79
Approx. Weight	Kg / Lb	3.5	7.7	3.5	7.7	3.8	8.4	6.7	14.7	9.8	21.6	12.8	28.2	17.8	39.2	27.3	60.1

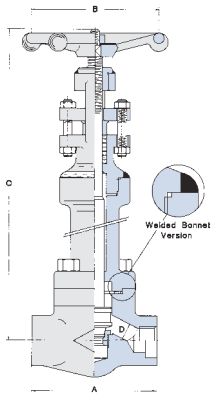

RATINGS: A182 - F304 - 3600 p.s.i. @ 100°F

CLASS 1500 BOLTED BONNET - REGULAR AND FULL PORT - BS 5352

Outside Screw & Yoke - Threaded and Socket Weld Ends

REGULAR PORT	CR-R930	-	1/2	3/4	1	1.1/4	1.1/2	2	-								
FULL PORT	CR-930	1/4	3/8	1/2	3/4	1	1.1/4	1.1/2	2								
		mm	in.	mm	in.	mm	in.	mm	in.	mm	in.	mm	in.	mm	in.	mm	in.
End to End	A	90	3.54	90	3.54	110	4.33	127	5.00	155	6.10	170	6.69	210	8.26	210	8.26
Handwheel	B	90	3.54	90	3.54	110	4.33	130	5.11	130	5.11	180	7.08	180	7.08	180	7.08
Center to Top Open	C	410	16.1	410	16.1	425	16.7	460	18.1	494	19.4	500	19.6	560	22.0	566	22.2
Dia. of Port	D	7	0.28	9	0.35	13	0.51	17	0.67	21	0.83	28	1.10	33	1.30	37.5	1.48
Approx. Weight	Kg / Lb	4.1	9.0	4.1	9.0	6.8	14.9	11.5	25.3	13.5	29.7	18.3	40.3	31.5	69.3	31	68.2

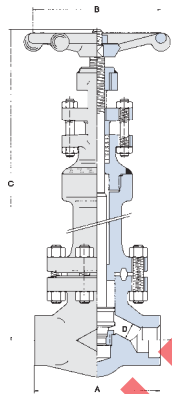

RATINGS: A182 - F304 - 3600 p.s.i. @ 100°F

CLASS 1500 ROUND BOLTED BONNET RJ - FULL PORT - BS 5352

Outside Screw & Yoke - Threaded and Socket Weld Ends

FULL PORT	CR-RJ930	1/4	3/8	1/2	3/4	1	1.1/4	1.1/2	2								
		mm	in.	mm	in.	mm	in.	mm	in.	mm	in.	mm	in.	mm	in.		
End to End	A	-	-	-	-	110	4.33	150	5.90	150	5.90	-	-	210	8.26	235	9.25
Handwheel	B	-	-	-	-	110	4.33	130	5.11	130	5.11	-	-	250	9.84	300	11.8
Center to Top Open	C	-	-	-	-	485	19.0	515	20.2	560	22.0	-	-	620	24.4	685	26.9
Dia. of Port	D	-	-	-	-	13	0.51	17	0.67	21	0.83	-	-	33	1.30	37.5	1.48
Approx. Weight	Kg / Lb	-	-	-	-	7.9	17.4	16.5	36.3	17.6	38.7	-	-	34	74.9	48.5	106.8

Spiral wound gasket joint available on request.

Ring-Joint gasket according to ANSI B16.20 - API 6A.

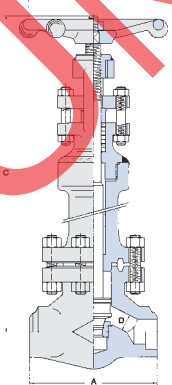

RATINGS: A182 - F304 - 6000 p.s.i. @ 100°F

CLASS 2500 ROUND BOLTED BONNET RJ - FULL PORT - BS16.34

Outside Screw & Yoke - Socket and Butt Weld Ends

FULL PORT	CR-RJ2530	1/4	3/8	1/2	3/4	1	1.1/4	1.1/2	2								
		mm	in.	mm	in.	mm	in.	mm	in.	mm	in.	mm	in.	mm	in.		
End to End	A	-	-	-	-	150	5.90	150	5.90	210	8.26	-	-	235	9.25	235	9.25
Handwheel	B	-	-	-	-	130	5.11	130	5.11	250	9.84	-	-	300	11.8	300	11.8
Center to Top Open	C	-	-	-	-	515	20.2	515	20.2	610	24.0	-	-	680	26.7	685	26.9
Dia. of Port	D	-	-	-	-	13	0.51	17	0.67	21	0.83	-	-	29.5	1.16	35	1.37
Approx. Weight	Kg / Lb	-	-	-	-	16.5	36.3	16.8	37.0	34.4	75.7	-	-	50	110.1	50	110.1

Ring-Joint gasket according to ANSI B16.20 - API 6A.

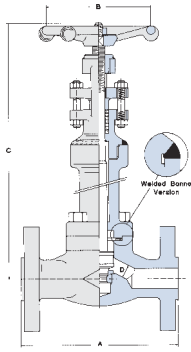

RATINGS: A182 - F304
 Class 150 - 275 p.s.i. @ 100°F
 Class 300 - 720 p.s.i. @ 100°F
 Class 600 - 1440 p.s.i. @ 100°F

CLASS 150-300-600

BOLTED BONNET - REGULAR PORT - BS 5352
 Outside Screw & Yoke - Integral Flanged Ends according to ANSI B16.5

REGULAR PORT		1/4		3/8		1/2		3/4		1		1.1/4		1.1/2		2	
		mm	in.	mm	in.	mm	in.	mm	in.	mm	in.	mm	in.	mm	in.	mm	in.
Class 150	CR-F1-830	A	-	-	-	108	4.25	118	4.64	127	5.00	-	-	165	6.49	203	7.99
Class 300	CR-F3-830	A	-	-	-	153	6.02	178	7.00	203	7.99	-	-	229	9.01	267	10.5
Class 600	CR-F6-830	A	-	-	-	165	6.49	191	7.51	216	8.50	-	-	241	9.48	292	11.5
Handwheel		B	-	-	-	90	3.54	90	3.54	110	4.33	-	-	130	5.11	180	7.08
Center to Top Open	Class 300-600	C	-	-	-	398	15.7	415	16.3	430	16.9	-	-	498	19.6	507	19.9
	Class 150	C	-	-	-	420	16.5	447	17.6	455	17.9	-	-	498	19.6	507	19.9
Dia. of Port		D	-	-	-	9	0.35	13	0.51	17.5	0.69	-	-	29.5	1.16	35	1.37
Approx. Weight	Class 150	Kg / Lb	-	-	-	5	11	5.8	12.7	8.6	18.9	-	-	13.8	30.4	24.3	53.5
	Class 300	Kg / Lb	-	-	-	5.8	12.7	6.8	14.9	10.3	22.6	-	-	19.3	42.5	25.8	56.8
	Class 600	Kg / Lb	-	-	-	6.3	13.8	7.3	16	10.6	23.3	-	-	20.3	44.7	26.8	59

End to End dimensions according to ANSI B16.10

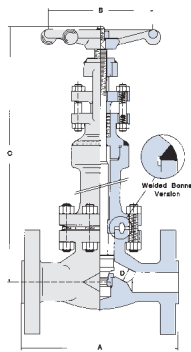

RATINGS: A182 - F304
 Class 150 - 275 p.s.i. @ 100°F
 Class 300 - 720 p.s.i. @ 100°F
 Class 600 - 1440 p.s.i. @ 100°F

CLASS 150-300-600

BOLTED BONNET RJ - FULL PORT - BS 5352
 Outside Screw & Yoke - Integral Flanged Ends according to ANSI B16.5

FULL PORT		1/4		3/8		1/2		3/4		1		1.1/4		1.1/2		2	
		mm	in.	mm	in.	mm	in.	mm	in.	mm	in.	mm	in.	mm	in.	mm	in.
Class 150	CR-1-630	A	-	-	-	108	4.25	118	4.64	127	5.00	-	-	165	6.49	203	7.99
Class 300	CR-F3-630	A	-	-	-	153	6.02	178	7.00	203	7.99	-	-	229	9.01	267	10.5
Class 600	CR-F6-630	A	-	-	-	165	6.49	191	7.51	216	8.50	-	-	241	9.48	292	11.5
Handwheel		B	-	-	-	90	3.54	110	4.33	130	5.11	-	-	250	9.84	250	9.84
Center to Top Open		C	-	-	-	495	19.4	523	20.6	545	21.4	-	-	660	25.9	690	27.1
Dia. of Port		D	-	-	-	13	0.51	17.5	0.69	22.5	0.89	-	-	35	1.37	45.5	1.79
Approx. Weight	Class 150	Kg / Lb	-	-	-	8.1	17.8	14.3	31.5	17.5	38.5	-	-	37.8	83.2	40.5	89.2
	Class 300	Kg / Lb	-	-	-	8.6	18.9	14.8	32.6	18.3	40.3	-	-	38.5	84.8	41	90.3
	Class 600	Kg / Lb	-	-	-	8.8	19.3	15	33.0	18.5	40.7	-	-	39	85.9	42	92.5

End to End dimensions according to ANSI B16.10

Spiral wound gasket joint and Welded Flanges for #150

Ring-Joint gasket according to ANSI B16.20 - API 6A

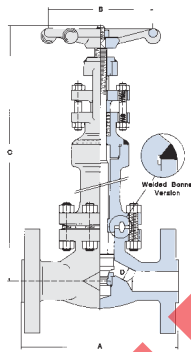

RATINGS: A182 - F304 - 3600 p.s.i. @ 100°F

CLASS 1500

ROUND BOLTED BONNET RJ - FULL PORT - BS 5352
 Outside Screw & Yoke - Integral Flanged Ends according to ANSI B16.5

FULL PORT		CR-F9-RJ930		1/4		3/8		1/2		3/4		1		1.1/4		1.1/2		2	
				mm	in.	mm	in.	mm	in.	mm	in.	mm	in.	mm	in.	mm	in.	mm	in.
End to End		A		-	-	-	-	216	8.50	229	9.01	254	10.0	-	-	305	12.0	368	14.5
Handwheel		B		-	-	-	-	110	4.33	130	5.11	130	5.11	-	-	250	9.84	300	11.8
Center to Top Open		C		-	-	-	-	510	20.0	550	21.6	550	21.65	-	-	640	25.2	670	26.3
Dia. of Port		D		-	-	-	-	13	0.51	17	0.67	21	0.83	-	-	33	1.30	37.5	1.48
Approx. Weight		Kg / Lb		-	-	-	-	13.8	30.5	21.5	47.3	25	55.0	-	-	46	101.3	73	160.8

End to End dimensions according to ANSI B16.10

Spiral wound gasket joint available on request

Ring-Joint gasket according to ANSI B16.20 - API 6A

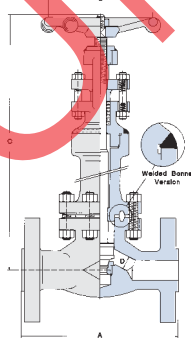

RATINGS: A182 - F304 - 6000 p.s.i. @ 100°F

CLASS 2500

ROUND BOLTED BONNET RJ - FULL PORT - B16.34
 Outside Screw & Yoke - Integral Flanged Ends according to ANSI B16.5

FULL PORT		CR-F25-RJ2530		1/4		3/8		1/2		3/4		1		1.1/4		1.1/2		2	
				mm	in.	mm	in.	mm	in.	mm	in.	mm	in.	mm	in.	mm	in.	mm	in.
End to End		A		-	-	-	-	264	10.4	273	10.7	308	12.1	-	-	384	15.1	451	17.7
Handwheel		B		-	-	-	-	130	5.11	130	5.11	250	9.84	-	-	300	11.8	300	11.8
Center to Top Open		C		-	-	-	-	582	22.9	582	22.9	620	24.4	-	-	685	26.9	820	32.2
Dia. of Port		D		-	-	-	-	11	0.43	17	0.67	21	0.83	-	-	33	1.30	37.5	1.48
Approx. Weight		Kg / Lb		-	-	-	-	25	55.0	27	59.4	54	118.9	-	-	77	169.6	107	235.6

End to End dimensions according to ANSI B16.10

Ring-Joint gasket according to ANSI B16.20 - API 6A

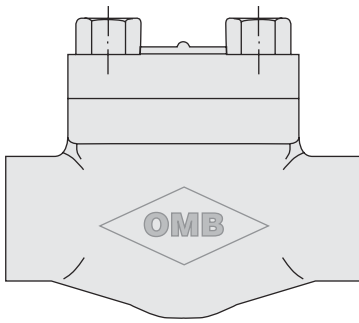

Check Valves are available in the following options:
 PISTON, BALL, SWING, Y PATTERN PISTON, Y PATTERN BALL

Class 150÷2500
 Size 1/4"÷2"
 Port Regular or Full
 Bonnet Bolted or Welded

Please refer to Catalog C12 for dimensions and weight

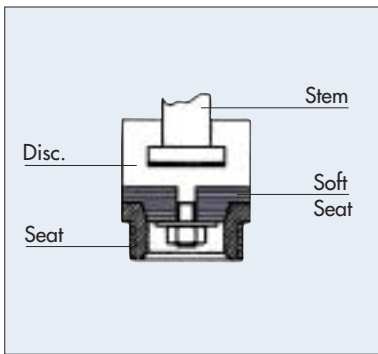

SOFT SEAT OPTION

Piston Check Valves and Globe Valves are available with PTFE and other type of insert.

Class, Sizes and other technical details are available on Catalog C12

Please specify temperature and rating in your request

LIP SEAL

One piece construction Lip-Seal ball valves is available in the following options:

Construction BS5351 and API 608
 Material Forged Steel (A105N, LF2, F304, F316)
 Design Floating Ball, Fire Safe tested, Anti BlowOut Stem
 Feature Double body Gasket, Seal Weld
 Class 800÷2500
 Size 1/4"÷2"
 Port Regular or Full

COMPACT

Three piece construction Compact ball valves is available in the following options:

Construction BS5351 and API 608
 Material Forged Steel (A105N, LF2, F304, F316)
 Design Floating Ball, Fire Safe tested, Anti BlowOut Stem
 Feature Easy maintenance, full disassembly
 Class 800÷1500
 Size 1/4"÷2"
 Port Regular or Full

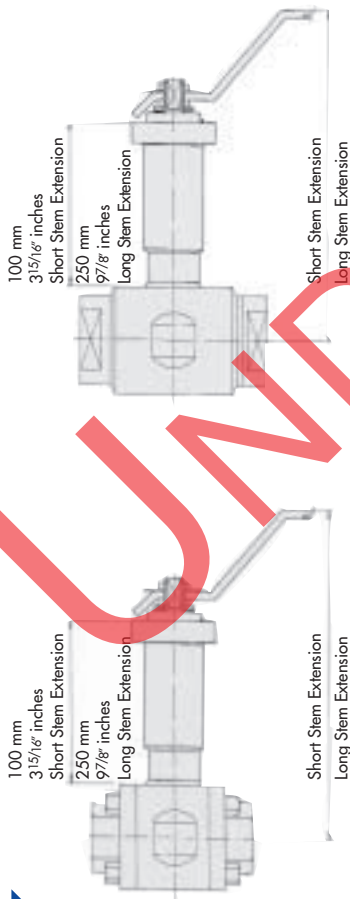



Other product lines



Bellows Seal Valves

OMB
Valves Specialist™

Gate, Globe & Eco-L-Valve®

ISO 9001

EN
QA

Since 1990



Forged steel
Ball Valves

API 6D
BS 5351

OMB
Fluicon Division

Floating & Trunnion

ISO 9001

EN
QA

Since 1990



Through Conduit Gate Valves

OMB
Valves Specialist™

API 6D & API 6A

ISO 9001

EN
QA

Since 1990



Forged Steel Valves

OMB
Valves Specialist™

Gate, Globe & Check

ISO 9001

EN
QA

Since 1990

C12





Valves spa

Valve Specialists

HEADQUARTERS

Via Europa
24069 Cenate Sotto,
(Bergamo) Italy
Phone ITALY 035 4256711
Fax ITALY 035 942638

www.ombvalves.com

WORLDWIDE NETWORK
OF AGENTS AND DISTRIBUTORS



WORLDWIDE SUBSIDIARIES

Americas inc.

HOUSTON, TX - U.S.A.
Phone +1-713-674-9511
Fax +1-713-675-2733

Americas inc.

MONTREAL - CANADA
Phone +1-514-457-0813
Fax +1-514-457-0814

Valves Asia Pte.Ltd.

WOODLAND - SINGAPORE
Phone +65-8522110
Fax +65-8521410

LOCAL AGENT: