

VELAN

HERMETICALLY-SEALED GATE AND GLOBE BELLOWS SEAL VALVES



**ALSO: BALL AND CONTROL VALVES
FOR EXTREME APPLICATIONS**

**SIZES: 1/2 - 12"
15 - 300 mm**

PROFILE

Velan is one of the world's leading manufacturers of industrial valves, supplying forged and cast steel gate, globe, check, ball, butterfly and knife gate valves for critical applications in the chemical, petrochemical, oil and gas, fossil and nuclear power, cogeneration, pulp and paper and cryogenic industries.

Founded in 1950, Velan earned a reputation for excellence as a major supplier of forged valves for nuclear power plants and the U.S. Navy. Velan Inc., pioneered many designs which became industry standards, **including bellows seal valves in 1954**, all stainless steel knife gate valves and forged valves up to 24".

Velan valves are manufactured in 12 specialized plants, including five in Canada, two in Korea and one each in the U.S., France, U.K., Portugal and Taiwan. We have a total of 1,091 employees in North America and 384 overseas.

CONTENTS

Bellows Seal Technology	2-5
Design Features	3
Compact Forged Steel	
Gate Valves, ½-2" (15-50 mm).....	6
Forged Steel Extended Body	
Gate Valves, ½-2" (15-50 mm).....	7
Cast Steel Gate Valves, 2-12" (50-300 mm)	8
Forged Steel Gate Valves, 2-6" (50-150 mm)	9
Compact Forged Steel	
Globe Valves, ½-2" (15-50 mm).....	10
Cast Steel Globe Valves, 2-8" (50-200 mm)	11
Forged Steel Y-Pattern Globe, ½-2" (15-50 mm).....	12
Forged Steel Globe Valves, 2½-8" (65-200 mm)	13
Ball Valves, ½-2" (15-50 mm)	14-15
Control Valves, ½-6" (15-150 mm).....	16
How to Order	17

HEAD OFFICE & PLANT 5



MONTREAL, CANADA 115,000 sq. ft. (10,683 m²)
3-12" (80-300 mm) butterfly and ¾-2" (10-50 mm) ball valves

MANUFACTURING LOCATIONS

U.S.A.

VELAN VALVE
CORPORATION
PLANT 3
94 Avenue C
Williston, VT
05495-9732
Tel: (802) 863-2562
Fax: (802) 862-4014

CANADA

VELAN INC.
HEAD OFFICE
PLANT 5
7007 Côte de Liesse
Montreal, QC H4T 1G2
Tel: (514) 748-7743
Fax: (514) 748-8635

PLANT 1
2125 Ward Avenue
Montreal, QC H4M 1T5
Tel: (514) 748-7743
Fax: (514) 748-8635

PLANT 2 / 7
550 McArthur Ave.
Montreal, QC H4T 1X8
Tel: (514) 748-7743
Fax: (514) 341-3032

PLANT 4 / 6
1010 Cowie Street
Granby, QC J2J 1E7
Tel: (450) 378-2305
Fax: (450) 378-6865

PROQUIP
835 Fourth Line
Oakville, ON L6L 5B8
Tel: (905) 842-1721
Fax: (905) 849-0923

FRANCE

VELAN S.A.S
90, rue Challemeil Lacour
F 69367 Lyon Cedex 7
France
Tel: (33) 4 78 61 67 00
Fax: (33) 4 78 72 12 18

ENGLAND

VELAN VALVES LTD.
Cambridge Rd.,
Whetstone
Leicester LE8 6LH
England
Tel: 44-116-275-0206
Fax: 44-116-275-0224

GERMANY

VELAN GmbH
Daimlerstrasse 8
D-47877 Willich
Germany
Tel: (49) 2154/4938-0
Fax: (49) 2154/4938-99

PORTUGAL

VELAN VÁLVULAS
INDUSTRIAIS, LDA.
Av. Ary dos Santos
1679-018 Famoses
Portugal
Tel: (351-21) 934-7800
Fax: (351-21) 934-7809

KOREA

VELAN LTD.
1060-4 Shingil-Dong
Ansan City, Kyunggi-do
Korea 425-120
Tel: (82) 31-491-2811
Fax: (82) 31-491-2813

TAIWAN

VELAN-VALVAC
P.O. Box 2020
Taichung, Taiwan, R.O.C.
Tel: (04) 2792649
Fax: (886) 42750855

**Velan has Sales offices and distributors located worldwide.
Visit the Velan website at www.velan.com for an updated contact list.**

GENERAL INFORMATION

Tel: (514) 748-7743
Fax: (514) 748-8635
Web: www.velan.com

NOTE: The material in this catalog is for general information. For specific performance data and proper material selection, consult your Velan representative. Although every attempt has been made to ensure that the information contained in this catalog is correct, Velan reserves the right to change designs, materials or specifications without notice.

MANUFACTURING PLANTS AROUND THE WORLD

PLANT 1



MONTREAL, CANADA 109,000 sq. ft. (10,126 m²) ¼–4" (8–100 mm) forged gate, globe & check valves, ASME 'N' stamp, ISO 9001

PLANT 2 & 7



MONTREAL, CANADA 170,000 sq. ft. (15,800 m²) 2–60" (50–1500 mm) forged and cast steel gate, globe, check, ball, knife and butterfly valves 3–36" (80–700 mm) ASME 'N' stamp, ISO 9001

PLANT 4 & 6



GRANBY, CANADA 186,500 sq. ft. (17,325 m²) 2–12" (50–300 mm) cast steel gate and check valves, ¼–12" (8–300 mm) ball valves, ISO 9001



TORONTO, CANADA *Velan-Proquip* 41,000 sq. ft. (3,800 m²) 2–48" (50–1200 mm) wafer check valves ½–24" (15–600 mm) clamp joint connectors, ISO 9001



WILLICH, GERMANY 12,000 sq. ft. (1,115 m²) ISO 9002



LEICESTER, ENGLAND 14,000 sq. ft. (1,300 m²), ISO 9002

PLANT 3



WILLISTON, VERMONT, U.S.A. 155,000 sq. ft. (14,400 m²) 2–24" (50–600 mm) forged and cast steel gate, globe and check valves, ASME 'N' stamp, ISO 9001



LYON, FRANCE 160,000 sq. ft. (14,900 m²) ¼–40" (8–1,000 mm) forged and cast steel gate, globe and butterfly valves, ISO 9001



LISBON, PORTUGAL 60,000 sq. ft. (5,600 m²) ISO 9002 2–12" (50–300 mm) cast steel gate, globe and check valves



ANSAN CITY, SOUTH KOREA Plant 1 30,000 sq. ft. (2,800 m²) components and 2–4" (50–100 mm) cast steel valves, ISO 9002



ANSAN CITY, SOUTH KOREA Plant 2 65,000 sq. ft. (5,800 m²) 2–12" (50–300 mm) cast steel gate, globe, check, ball and knife gate valves



TAICHUNG, TAIWAN *Velan-Valvac* 20,000 sq. ft. (1,840 m²) ¼–2" (8–50 mm) ball valves, ISO 9002

VELAN BELLOWS SEAL VALVES

SUPERIOR PERFORMANCE BASED ON 45 YEARS OF EXPERIENCE

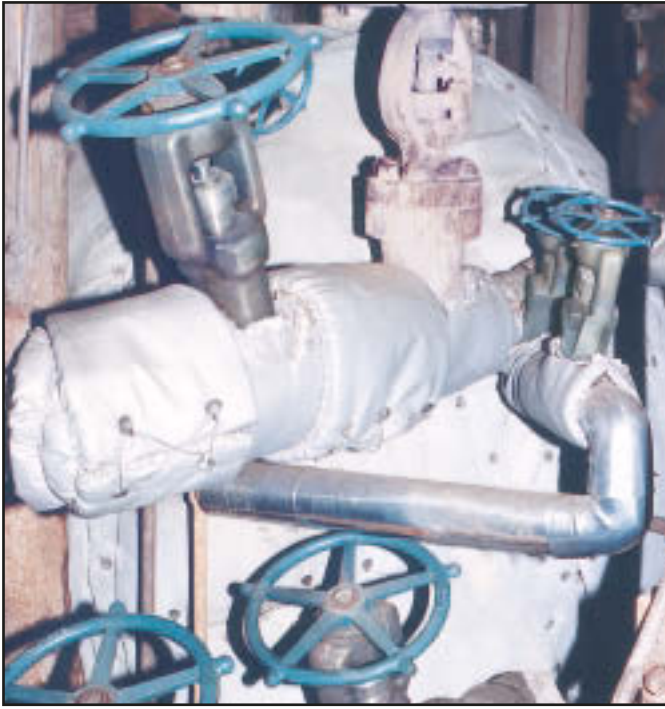

2500 Class HP/HT Bonnetless Globe Valves in power stations (see page 11).

OVERALL DESIGN FEATURES:

- **No torsion of bellows.**
Non-rotating stem prevents torsion of bellows and ensures long cycle life on all valves.
- **Long cycle life bellows.**
Designed for and successfully tested in high pressure/temperature applications.
- **Low torque** due to non-rotating stem, central grease fitting for lubrication of stem nut and for high pressure valves, stem thrust bearing.
- **Two secondary stem seals:**
 - a) backseat (stem bevel) protects from line pressure when open and
 - b) stem packing.
- **Hermetically sealed.** Body-bonnet welds provide a hermetically-enclosed vessel in most designs.
- **In-line servicing.** Stem-bellows assembly can easily be removed and replaced on valves with bolted bonnet. On seal-welded valves, removal and replacement of weld is necessary. Special power tools are available for cutting seal weld.

QUALIFICATION TESTING



Hot loop for cycling four bellows seal valves at 1800 psig @ 650°F (124 bar @ 343°C).

VELAN R&D QUALIFICATION TESTING

Extensive bellows seal qualification testing has been performed in the research and development department to prove the bellows cycle life.

Velan bellows seal valves are designed with a minimum of two plies. Multi-ply bellows are superior to single ply and diaphragm (welded construction) bellows.

MULTI-PLY

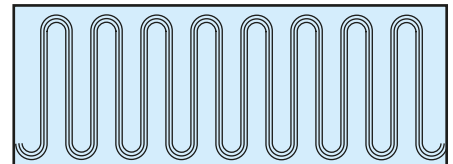

BELLOWS DESIGN PARAMETERS

DESIGN PARAMETERS

Velan valves feature a formed multi-ply bellows welded to the stem and to the bottom of the bonnet, creating a hermetic seal or impermeable barrier. Bellows are available in stainless steel, Inconel, Hastelloy C and Monel for virtually all corrosive chemical applications.

CYCLE LIFE

- Axial movement of the bellows is limited to a maximum of 20–25% of the free length, depending on pressure/ temperature and desired life cycle.

Velan bellows are designed for:

10,000 cycles

for ½–2" (15–50mm)

Class 800 globe valves,

5,000 cycles

for ½–2" (15–50mm)

Y-pattern ASME Class 1500-2500 valves, and

3,000 cycles for ½–2" (15–50mm) gate valves.

Large valves, sizes 2½–12" (65–300mm) are offered with **3,000** life cycles for globe, and **2,000** cycles for gate valves.

- The bellows stroke is 50% in tension and 50% in compression.
- Proper stem guiding eliminates torsion of bellows.
- Stroke limitation for long bellows. To accommodate long lift for larger gate valves, two or three bellows are joined and each takes over part of the lift.

GEOMETRY OF BELLOWS DESIGN

- Two basic parameters are used in design of the form of bellows:

1. **A** - relation between radius R_1 , thickness t and movement of one corrugation d .

$$A = (Rt)^\alpha \text{ where } \alpha = \frac{d}{0.785}$$

2. **B** = ellipticity or $B = \frac{a}{h}$

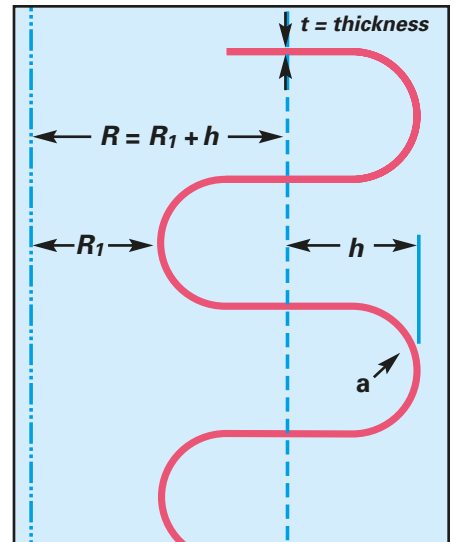

Increase in radius R and thickness t reduces stress during deflection.

- Velan uses multi-ply bellows in SS 321 and Inconel up to Class 1500, and Hastelloy C for Class 2500 valves.
- A useful equation for relating stress S_B in psi to the number of cycles to failure N is:

$$N = (1,600,000/S_B)^{3.5}$$

APPLICATIONS

- Reliability and total containment of toxic and aggressive fluids is achieved with bellows sealed stem and seal-welded body-bonnet joint.
- Operators, the public and the environment are protected from packing and gasket leakage.
- Maintenance-free service for 2,000 to 10,000 cycles.
- Ideal for steam, which is difficult to contain and where loss of energy is very costly.
- Bellows sealed valves are currently in use in difficult and toxic services for the following fluids:

Acrylonitrile	Ethyl Mercaptan	Phosgene
Ammonia	Freon	Potassium (liquid)
Argon	Helium	Sodium (liquid)
Benzene	Hydrogen	Steam
Carbon Dioxide	Hydrogen Bromide	Sulfuric Acid
Caustic Solutions	Hydrogen Chloride	Titanium Tetrachloride
Chlorine	Hydrogen Sulfide	Toluene
Heat transfer oils/media	Hydrofluoric Acid (HF)	Vinyl Chloride
Dowtherm	Nitrogen	

Also for sour gas and oil, cryogenic and vacuum service.



Class 2500 hermetically-sealed Y-pattern bellows sealed valves.

HIGHLIGHTS OF BELLOWS

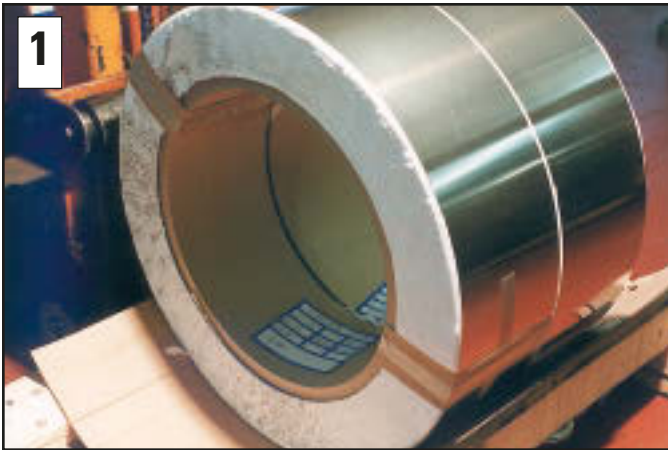

Raw material for multi-ply bellows (Gr. 321 stainless steel, Inconel or Hastelloy C), tested for intergranular corrosion, tensile and elongation.

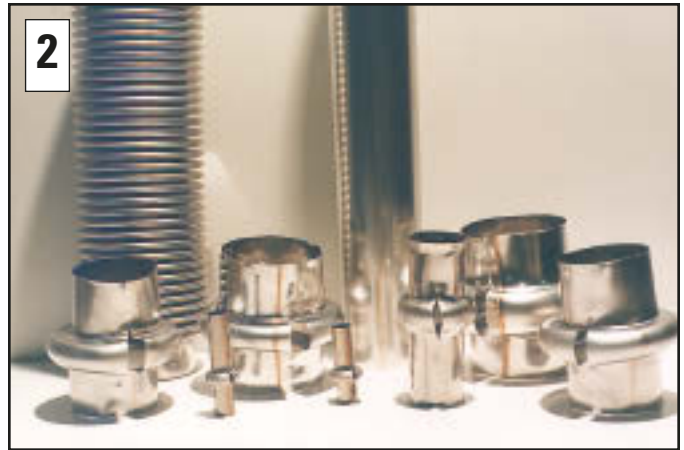

In-line inspection of tube welding prior to convolution forming.

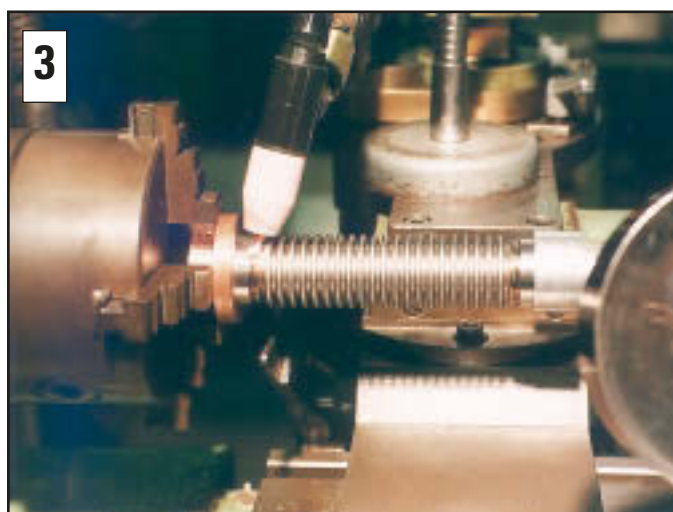

Microplasma welding of bellows.



Laser welding of bellows to end rings.

*Photos courtesy
of Witzenmann GmbH*

PRODUCTION AND TESTING

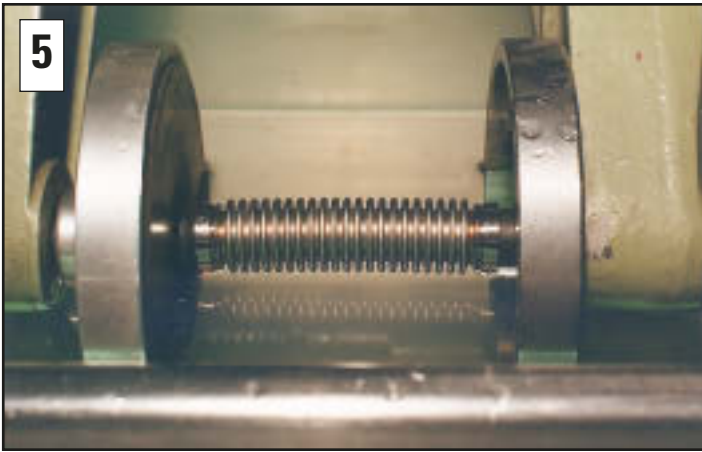

5 Nitrogen bubble test under water.

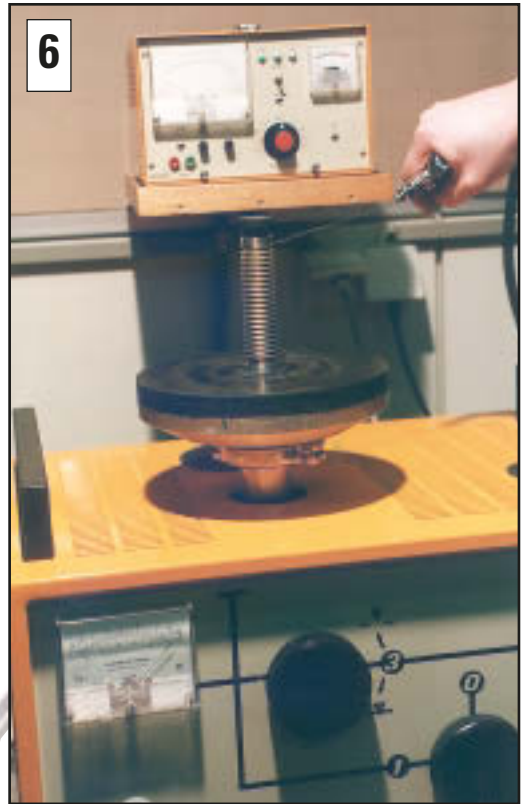

6 Helium leak testing. Bellows are rejected if leakage exceeds 10^{-8} cm³ per second.



7 Spring rate test verifies force needed to compress bellows.

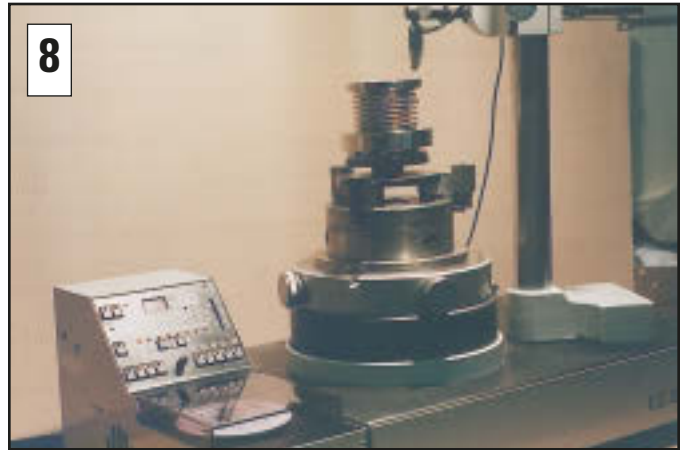

8 Concentricity testing of bellows, end fittings.



COMPACT FORGED STEEL BELLOWS SEAL GATE VALVES

THREADED, SOCKET WELD OR FLANGED 1/2–2" (15–50 mm)
API 602, CLASSES 800, 1500, ASME CLASSES 150–1500

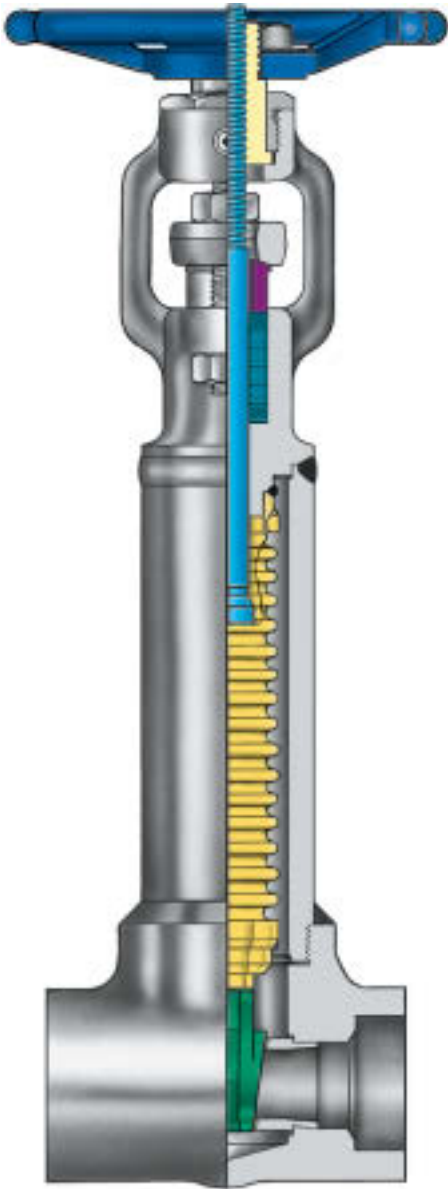

DESIGN FEATURES:

- **Long cycle life bellows (3000 cycles).**
Designed and qualification-tested for high pressure/temperature service.
- **Bellows monitoring port (optional).** A plug can be connected with the space above the bellows to monitor performance.
- **Two secondary stem seals:**
 - a) Backseat in open position
 - b) Graphite packing.
- **Superior seating faces.**
Seats hardfaced with Stellite 6 and wedge is solid Stellite 6.

All standard valves available in A 105N, A 182 Gr. F22 & Gr. F316.

TYPICAL A 105 VALVE PARTS LIST

Part	Standard Materials
Body	A 105N
Body Extension	Steel ASTM A 106 Gr. B
Seat	Gr. 410 (stainless) HF
Wedge	Stellite 6
Bonnet	A 105N
Stem	Gr. 410 (stainless)
Packing rings	Graphite
Bellows ⁽¹⁾	Gr. 321 (stainless)
Gland stud	Gr. B6 (stainless)
Gland nut	Gr. 2H (stainless)
Gland	Gr. 416 (stainless)
Packing flange	A 105
Stem nut	Gr. 416 (stainless)
Yoke bushing	Steel
Handwheel	Malleable iron (painted)
Stem nut	Steel
Handwheel Lock washer	Steel
Name plate	Aluminum

(1) Hastelloy C and Inconel 625 also available.

A bolted bonnet version with provision for seal welding is available for nuclear and other applications.

Optional body, trim and bellows materials available on request.

PRESSURE/TEMPERATURE RATINGS

Material	Temp. °F °C	Working Pressure psig bar		Shell Test Pressure psig bar	
		800	1500	800	1500
A 105N	100 38	1975 136	3705 256	2975	5575
	800 427	1100 76	2060 142		
A 182 Gr. F 316	100 38	1920 132	3600 248	2900	5400
	1000 538	935 64	1750 121		

FIGURE NUMBERS

Class	Figure No.
150	0054T
300	1054T
600/800	2054T
1500	3054T

DIMENSIONS AND WEIGHTS

Size in mm	Port		End to End		Handwheel		Center to Top Open		Center to Top Closed		Socket Weld Bore	Socket Weld Depth	End to End (Flanged)				Weight lb kg	
	800	1500	800	1500	800	1500	800	1500	800	1500			150	300	600	1500	800	1500
1/2 ⁽¹⁾ 15	0.38 10	0.50 13	2.88 73	3.50 89	2.50 64	3.50 89	7.20 183	13.50 343	6.70 170	12.88 327	0.855 21.72	0.38 10	4.25 108	5.50 139	6.50 165	8.50 216	3 1.4	8 3.6
3/4 20	0.50 13	0.50 13	3.25 83	3.50 89	3.50 89	3.50 89	11.25 286	13.50 343	10.63 270	12.88 327	1.065 27.05	0.50 13	4.63 118	6.00 152	7.50 191	9.00 229	6 2.7	8 3.6
1 25	0.69 18	0.69 18	3.50 89	5.00 127	3.50 89	5.00 127	12.56 319	17.00 431	11.75 298	16.19 411	1.330 33.78	0.50 13	5.00 127	6.50 165	8.50 216	10.00 254	7 3.2	17 7.7
1 1/4 32	1.25 32	1.25 32	5.00 127	5.25 133	6.00 152	8.00 203	15.50 393	22.63 575	14.13 359	21.25 540	1.675 42.55	0.50 13	5.50 140	7.00 178	9.00 227	11.00 279	16 7.3	32 14.6
1 1/2 40	1.25 32	1.25 32	5.00 127	5.25 133	6.00 152	8.00 203	15.50 393	22.63 575	14.13 359	21.25 540	1.915 48.64	0.50 13	6.50 165	7.50 191	9.50 241	12.00 305	16 7.3	32 14.6
2 50	1.50 38	1.50 38	5.25 133	10.00 254	6.00 152	10.00 254	17.81 452	25.94 659	16.13 410	24.25 616	2.406 61.11	0.63 16	7.00 178	8.50 221	11.50 292	14.50 368	22 10	60 27

(1) All dimensions are for A 105N and F316 only. For other materials see 3/4" (20 mm) dimensions.



FORGED STEEL BELLOWS SEAL EXTENDED BODY GATE VALVES,

CONVENTIONAL PORT, THREADED OR SOCKET WELD FEMALE
½-2" (15-50 mm), API 602, CLASSES 800, 1500

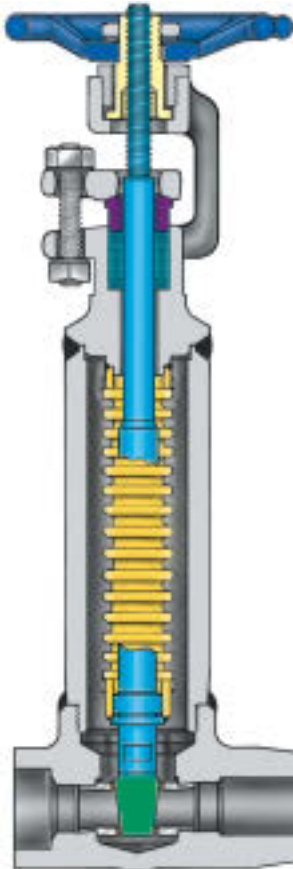

DESIGN FEATURES:

- **Long cycle life bellows (3000 cycles).**
Gr. 321 (stainless) for Class 800,
Gr. 321 or Inconel for Class 1500,
and Hastelloy C for chlorine service.
Optional materials available on request.
Designed and qualification-tested for
high pressure/temperature service.
- **Bellows monitoring port (optional).**
A plug can be connected with
the space above the bellows
to monitor performance.
- **Two secondary stem seals:**
a) Backseat in open position
b) Graphite packing.
- **Superior seating faces.**
Seats hardfaced with Stellite 6
and wedge is solid Stellite 6.

APPLICATIONS:

The drain valve has a welded or threaded connection and is used for tapping of pressure vessels and header lines for vents, drains, or take-off lines and instrumentation.

TWO TYPES:

The valves are available with a standard extended body or integrally-reinforced extended body ("IREB" valves).

For Standard Materials Table see page 6.

FIGURE NUMBERS

Class	Standard	IREB
800	2184T	2174T
1500	3184T	3174T

AVAILABLE VARIATIONS

END CONNECTION	IREB	STANDARD
Female thread	Male weld end	Male thread Male plain
Female socket weld	Male weld end	Male plain

PRESSURE/TEMPERATURE RATINGS

Material	Temp. °F °C	Working Pressure psig bar		Shell Test Pressure psig bar	
		800	1500	800	1500
A 105N	100	1975	3705	2975	5575
	38	136	256		
	800	1100	2060		
	427	76	142	205	384
A 182 Gr. F 316	100	1920	3600	2900	5400
	38	132	248		
	1000	935	1750		
	538	64	121		

STANDARD DIMENSIONS

Size in mm	Port	End to End		Male End				Handwheel		Socket Weld Bore	Socket Weld Depth	Center to Top Open		Center to Top Closed		Weight lb kg	
				OD	ID	Length from Center						800	1500	800	1500	800	1500
		800	1500														
½ 15	0.50 13	5.63	5.75	0.84	0.63	4.00	4.00	3.50	3.50	0.885	0.38	11.25	13.50	10.63	12.88	6.5	12.0
		143	146	21.33	16.0	102	102	89	89	21.72	10	286	343	270	327	3.0	5.5
¾ 20	0.50 13	5.63	5.75	1.05	0.63	4.00	4.00	3.50	3.50	1.065	0.50	11.25	13.50	10.63	12.88	6.5	12.0
		143	146	26.67	16.0	102	102	89	89	27.05	13	286	343	270	327	3.0	5.5
1 25	0.69 18	5.75	6.50	1.32	0.84	4.00	4.00	3.50	5.00	1.330	0.50	12.56	17.00	11.75	16.19	7.5	18.0
		146	165	33.53	21	102	102	89	127	33.78	13	319	432	298	411	3.4	8.1
1½ 40	1.25 32	7.25	7.88	1.90	1.50	4.75	5.25	6.00	8.00	1.915	0.50	15.50	22.63	14.13	20.25	17.0	29.0
		184	200	48.26	38.1	121	133	152	203	48.64	13	394	575	359	514	7.7	13.2
2 50	1.50 38	7.88	12.25	2.38	1.69	5.25	7.25	6.00	10.00	2.406	0.63	17.81	26.00	16.13	24.25	26.0	62.0
		200	311	60.45	42.9	133	184	152	254	61.11	16	450	660	410	616	11.8	28.1

IREB DIMENSIONS

Size in mm	Port	End to End		Male End				Handwheel		Socket Weld Bore	Socket Weld Depth	Center to Top Open		Center to Top Closed		Weight lb kg	
				OD	ID	Length from Center						800	1500	800	1500	800	1500
		800	1500														
½ 15	0.50 13	8.63	8.88	0.97	0.75	7.00	7.13	3.50	3.50	0.885	0.38	11.25	13.50	10.63	12.88	8	14
		219	226	24.6	19.1	178	181	89	89	21.72	10	286	343	270	327	3.6	6.3
¾ 20	0.50 13	8.63	8.88	0.97	0.75	7.00	7.13	3.50	3.50	1.065	0.50	11.25	13.50	10.63	12.88	8	14
		219	226	24.6	19.1	178	181	89	89	27.05	13	286	343	270	327	3.6	6.3
1 25	0.69 18	9.38	10.13	1.22	1.00	7.63	7.63	3.50	5.00	1.330	0.50	12.56	17.00	11.75	16.19	9.5	21
		238	258	31.0	25.4	194	194	89	127	33.78	13	319	432	298	411	4.3	9.5
1½ 40	1.25 32	10.50	10.63	1.72	1.50	8.00	8.00	6.00	8.00	1.915	0.50	15.50	22.63	14.13	21.25	20	33
		267	270	43.7	38.1	203	203	152	203	48.64	13	394	575	359	540	9.1	15.0
2 50	1.50 38	11.88	14.25	2.22	1.69	9.25	9.25	6.00	10.00	2.406	0.63	17.81	25.94	16.13	24.25	29.5	68
		302	362	56.4	42.9	235	235	152	254	61.11	16	452	659	410	616	13.4	30.8



CAST STEEL BELLOWS SEAL BOLTED BONNET GATE VALVES

FLANGED OR BUTT WELD 2–12" (50–300 mm)
API 600, ASME CLASSES 150, 300, 600
WITH OPTIONAL PROVISION FOR SEAL WELDING

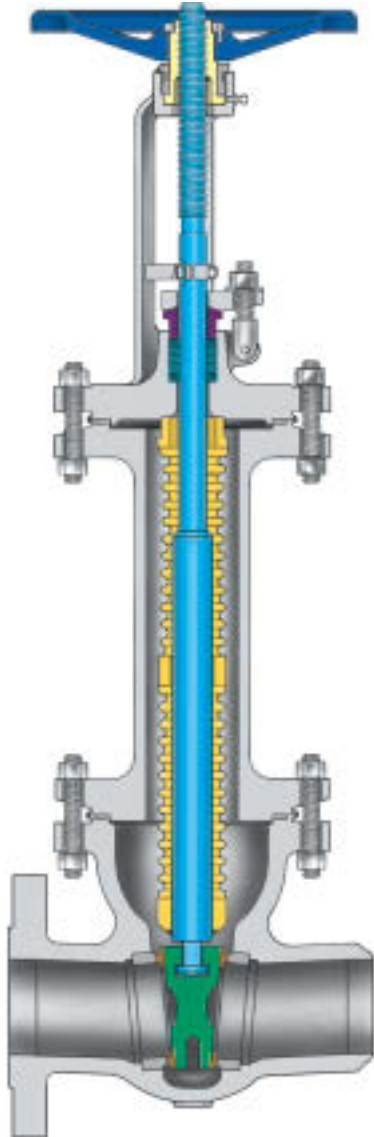

DESIGN FEATURES:

- **Long cycle life bellows (2000 cycles)** in Gr. 321 (stainless), Inconel for special applications, maybe replaced with Monel trim to resist corrosion or Hastelloy C for chlorine service.
- **Improved body-bonnet joint.** Graphite reinforced with SS foil gasket for Class 150 valves. Fully-encased, spiral wound graphite-filled Gr. 316 (stainless) gasket for Classes 300-600.
- **Bolted body-bonnet** for fast serviceability. Hermetically-sealed bonnets available for Classes 300 and 600.
- **Two or three section bellows assembly.**
- **Non-rotating stem** prevents torsion of bellows.
- **Two secondary stem seals:**
 - a) Backseat in open position
 - b) Graphite packing.
- **Welded-in seat** hardfaced with Stellite 6.
- **Wedge hardfaced** with Stellite 6 for long life.
- **Seating faces hardfaced** with Stellite 6, ground and lapped.

STANDARD MATERIALS

Part	Carbon steel	Stainless steel
Body/bonnet	A 216 Gr. WCB	A 351 Gr. CF8M
Wedge	Stellite faced	Stellite faced
Seats	Stellite faced A 105	Stellite faced CF8M
Stem	Gr. 13 CR	Gr. 316
Bellows	Gr. 321 (stainless) or Inconel	
Stem nut	Austenitic ductile iron A 439 Gr. D-2C	
Packing	Graphite	

FIGURE NUMBERS

Class	Figure No.
150	0064V
300	1064V
600	2064V

Available in A 216 Gr. WCB, A 217 Gr. C5, A 352 Gr. LCB and A 351 Gr. CF8M.

PRESSURE/TEMPERATURE RATINGS

Material	Temp. °F °C	Working Pressure psig bar			Shell Test Pressure psig bar		
		150	300	600	150	300	600
		A 216 Gr. WCB	100 38	285 20	740 51	1480 102	450 31
A 351 Gr. CF8M	100 38	275 19	720 50	1440 99	425 29	1100 76	2175 150
	1000 538	20 1.4	350 24	700 48			

DIMENSIONS AND WEIGHTS

Size in mm	Class 150							Class 300							Class 600						
	Center to Top		Face to Face		Weight		Center to Top	Center to Top	Face to Face		Weight		Center to Top	Center to Top	Face to Face		Weight				
	Closed	Open	BW	FL	BW	FL			BW	FL	BW	FL			BW	FL	BW	FL	BW	FL	
							Closed	Open					Closed	Open							
2	28.92	31.27	8.50	7.00	95	101	28.87	31.25	8.50	8.50	99	113	34.00	36.38	11.50	11.50	128	140			
50	735	794	216	178	43	46	733	794	216	216	45	51	864	924	292	292	58	64			
2½	31.17	33.93	9.50	7.50	104	111	30.62	33.38	9.50	9.50	108	123	35.75	38.75	13.00	13.00	143	156			
65	792	862	241	191	47	50	778	848	241	241	49	56	908	984	330	330	65	71			
3	31.25	35.37	11.13	8.00	120	131	30.62	34.37	11.13	11.13	150	175	36.00	39.75	14.00	14.00	177	204			
80	794	898	283	203	54	59	778	873	283	283	68	79	914	1010	356	356	80	93			
4	36.00	40.37	12.00	9.00	156	178	35.50	39.87	12.00	12.00	196	226	42.31	46.81	17.00	17.00	325	376			
100	914	1025	305	229	71	81	902	1013	305	305	89	103	1075	1189	432	432	148	171			
6	52.00	58.87	15.88	10.50	318	339	52.00	58.50	15.88	15.88	375	445	56.94	63.44	22.00	22.00	630	776			
150	1321	1495	403	267	145	154	1321	1486	403	403	170	202	1446	1611	559	559	286	352			
8	59.25	67.75	16.50	11.50	484	541	59.50	68.19	16.50	16.50	579	688	74.00	82.75	26.00	26.00	1004	1162			
200	1505	1721	419	292	220	246	1511	1732	419	419	263	312	1880	2102	660	660	456	527			
10	70.44	81.31	18.00	13.00	782	827	70.50	80.75	18.00	18.00	929	1070	90.00	100.25	31.00	31.00	1408	1688			
250	1789	2065	457	330	355	376	1791	2051	457	457	422	485	2286	2546	787	787	639	766			
12	80.53	93.03	19.75	14.00	1116	1167	78.25	91.12	19.75	19.75	1217	1465	104.00	116.75	33.00	33.00	1807	2129			
300	2045	2363	502	356	507	530	1988	2314	502	502	553	665	2642	2966	838	838	820	966			



FORGED STEEL BELLOWS SEAL BOLTED BONNET GATE VALVES

2–6" (50–150 mm) ASME CLASSES 600, 1500
WITH OPTIONAL PROVISION FOR SEAL WELDING

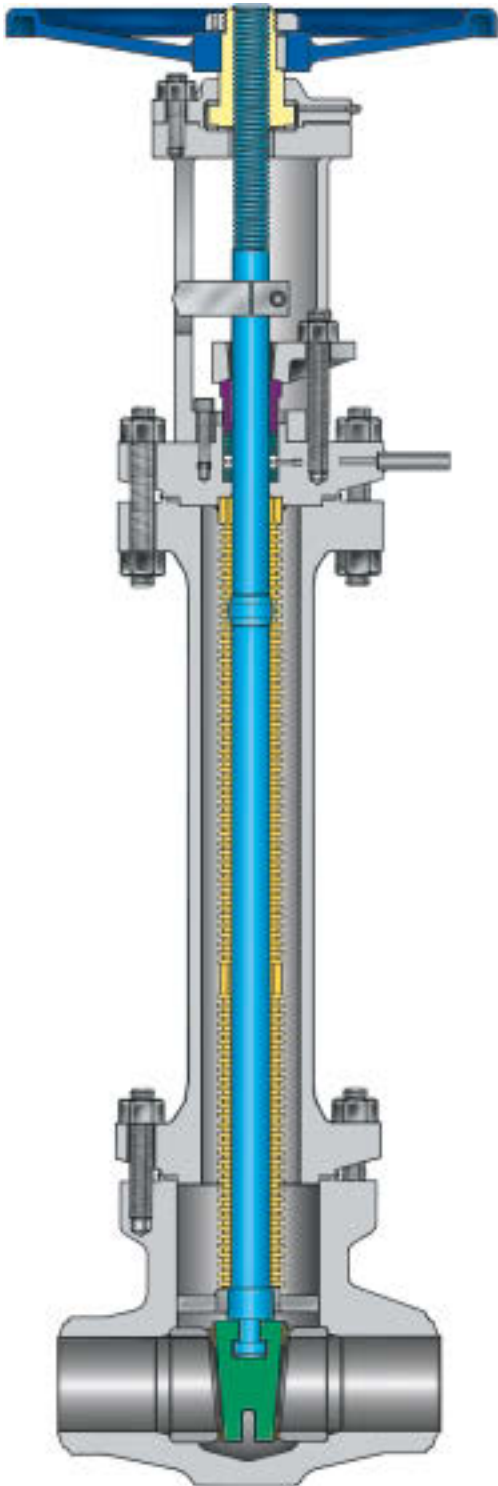

DESIGN FEATURES:

- **Long cycle life bellows (2000 cycles)** in Gr. 321 (stainless) or Inconel. Designed for, and successfully tested in, high pressure/temperature conditions.
- **Bellows monitoring port** (optional). Connected to the space above the bellows to monitor performance.
- **Non-rotating stem** prevents torsion of bellows.
- **Two secondary stem seals:**
 - a) Backseat in open position.
 - b) Graphite packing.
- **Forged for higher safety.** Increased toughness, strength and fatigue resistance.
- **Two-part bellows.**
- **Low torque.**
 - a) Non-rotating stem prevents torsion of bellows
 - b) Stem nut thrust bearings
 - c) Central lubrication
- **Seating faces hardfaced** with Stellite 6, ground and lapped.

STANDARD MATERIALS

Part	Carbon steel	Stainless steel
Body/ bonnet	A 105	A 182 Gr. F316
Wedge	Stellite faced	Stellite faced
Seats	Stellite faced A 105	Stellite faced CF8M
Stem	Gr. 13 CR	Gr. 316
Bellows Stem nut	Gr. 321 (stainless) or Inconel Manganese bronze	
Packing	Graphite	

PRESSURE/TEMPERATURE RATINGS

Material	Temp. °F °C	Working Pressure psig bar			Shell Test Pressure psig bar		
		600	900	1500	600	900	1500
A 105	100	1480	2220	3705	2225	3350	5575
	38	102	153	256			
A 182 Gr. F316	800	825	1235	2060	153	231	384
	427	57	85	142			
A 182 Gr. F316	100	1440	2160	3600	2175	3250	5400
	38	99	149	248			
A 182 Gr. F316	1000	700	1050	1750	150	224	372
	538	48	72	121			

FIGURE NUMBERS

Class	Figure No.
600	2054R
900	7054R
1500	3054R

DIMENSIONS AND WEIGHTS

Size in mm	Center to Top Closed			End to End (Butt Weld)			Weight (Butt Weld)		
	in mm	in mm	in mm	in mm	in mm	in mm	lb kg	lb kg	lb kg
	600	900	1500	600	900	1500	600	900	1500
2	25	30	36	8.50	8.50	8.50	120	138	145
50	635	762	914	216	216	216	59	63	66
2½	35	42	50	10	10	10	130	150	170
65	889	1067	1270	254	254	254	59	68	77
3	47	56	67	12	12	12	260	290	330
80	1194	1422	1702	305	305	305	118	132	150
4	57	68	81	12	14	16	325	350	380
100	1448	1727	2057	305	356	406	148	159	172
6	67	80	96	18	20	22	1040	1160	1380
150	1702	2032	2438	457	508	559	472	526	626

All valves available in A 105N,
A 182 Gr. F22 or Gr. F316.



COMPACT FORGED STEEL BELLOWS SEAL GLOBE VALVES

½–2" (15–50 mm)

API 602 CLASS 800, ASME CLASSES 150 – 800

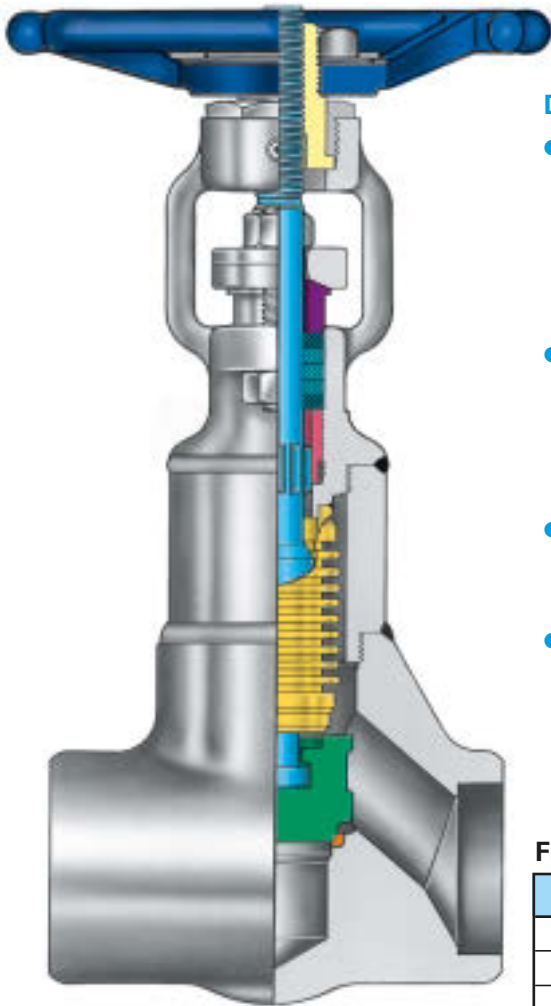

DESIGN FEATURES:

- **Long cycle life bellows (10,000 cycles).**
Designed and qualification-tested for high pressure/temperature applications.
- **Bellows monitoring port (optional).** A plug can be connected to the space above the bellows to monitor performance.
- **Two secondary stem seals:**
a) Backseat in open position
b) Graphite packing.
- **Superior seating faces.**
Seats hardfaced with Stellite 6, disc is solid Stellite 6.

TYPICAL A 105 VALVE PARTS LIST

Part	Standard Materials
Body	A 105N
Body extension	Steel ASTM A 106 Gr. B
Seat	Stellite (integral)
Disc	Stellite 6
Bonnet	A 105N
Stem	Gr. 410 (stainless)
Packing rings	Graphite
Bellows	Gr. 321 (stainless)
Gland stud	Gr. B6 (stainless)
Gland nut	Gr. 2H (stainless)
Gland	Gr. 416 (stainless)
Packing flange	A 105
Stem nut	Gr. 416 (stainless)
Yoke bushing	Steel
Handwheel (painted)	Malleable iron
Handwheel nut	Steel
Handwheel lock washer	Steel
Name plate	Aluminum

FIGURE NUMBERS

Class	Figure No.
150	0074T
300	1074T
600/800	2074T

All standard valves available in A 105N, A 182 Gr. F22 and Gr. F316.

Optional body, trim and bellows materials available on request.

PRESSURE/TEMPERATURE RATINGS

Material	Temp. °F °C	Working Pressure	Shell Test Pressure
		psig bar	psig bar
A 105N	100	1975	2975
	38	136	
	800	1100	205
A 182 Gr. F316	427	76	2900
	100	1920	
	38	132	
	1000	935	200
	538	64	

DIMENSIONS AND WEIGHTS

Size in mm	Port	End to End	Handwheel	Socket Weld Bore	Socket Weld Depth	Center to Top Open	Center to Top Closed	Approx. Weight lb kg	End to End (Flanged)		
									150	300	600
½ ⁽¹⁾ 15	0.31 8	2.88 73	2.50 64	0.855 21.72	0.38 10	7.00 178	6.70 178	6 2.7	4.25 108	6.00 152	6.50 165
¾ 20	0.50 13	3.25 83	3.50 89	1.065 27.05	0.50 13	9.00 229	8.75 222	6 2.7	4.63 117	7.00 178	7.50 191
1 25	0.75 19	3.50 89	3.50 89	1.330 33.78	0.50 13	10.10 257	9.80 249	7 3.2	5.00 127	8.00 203	8.50 216
1¼ 32	1.25 32	5.00 127	6.00 152	1.675 42.55	0.50 13	12.31 313	12.00 305	14 6.3	5.50 140	8.50 216	9.00 229
1½ 40	1.25 32	5.00 127	6.00 152	1.915 48.64	0.50 13	12.31 313	12.00 305	14 6.3	6.50 165	9.00 229	9.50 241
2 50	1.38 35	5.25 133	6.00 152	2.406 61.11	0.63 16	14.69 373	14.25 362	19 8.6	8.00 203	10.50 267	11.50 292

(1) All dimensions are for A 105N and F316 only. For other materials see ¾" (20 mm) dimensions.



CAST STEEL BELLOWS SEAL BOLTED BONNET GLOBE VALVES

2–8" (50–200 mm) API 600, ASME CLASSES 150, 300, 600

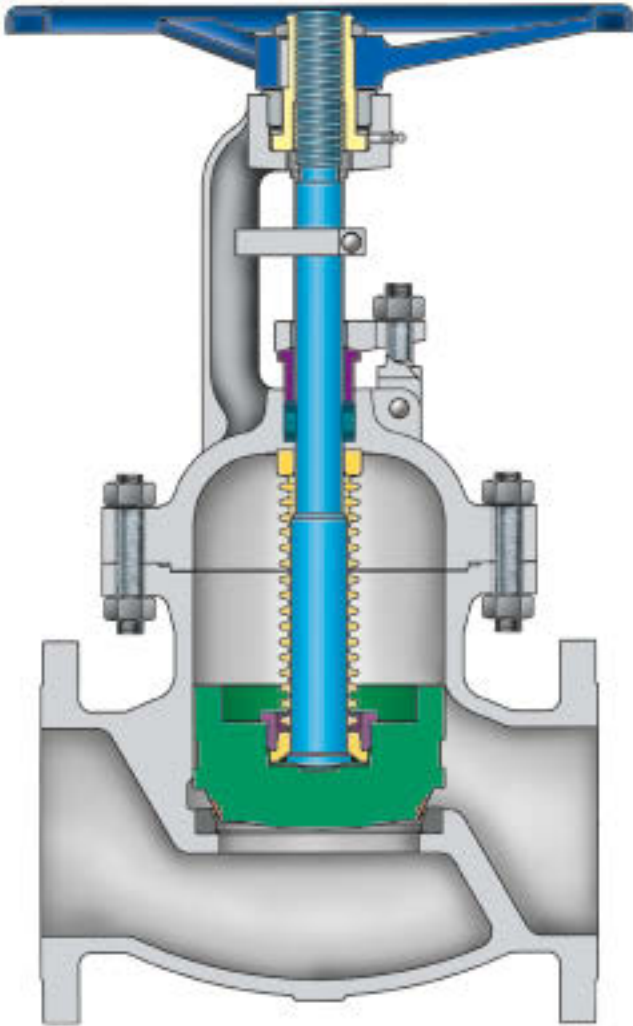

Available in A 216 Gr. WCB, A 217 Gr. WC6, A 217 Gr. C5, A 352 Gr. LCB and A 351 Gr. CF8M.

DESIGN FEATURES:

- **Long cycle life bellows (3000 cycles)**
in Gr. 321 (stainless), Inconel for special applications, or Hastelloy C for chlorine service.
- **Bolted body-bonnet joints** for fast serviceability. Fully enclosed spiral wound Gr. 316 (stainless) graphite gaskets.
- **Non-rotating stem** prevents torsion of bellows.
- **Two-secondary stem seals:**
a) Back seat in open position. b) Graphite packing.
- **Bellows monitoring port** (optional). A plug can be connected to the space above the bellows to monitor performance.
- **Seat and disc hardfaced with Stellite 6**, ground and lapped.

STANDARD MATERIALS

Part	Carbon Steel	Stainless Steel
Body/bonnet	A 216 Gr. WCB	A 351 Gr. CF8M
Stem	Gr. 13 CR	Gr. 316
Disc ⁽¹⁾	CA-15 or 13CR or A 105 HF	CF8M HFor F316 HF
Bellows	Gr. 321 (stainless), Inconel or Hastelloy	
Bellows fitting	Gr. 321 (stainless)	
Packing	Graphite	
Seat	Integral hardfaced Stellite 6	
Stem nut	Manganese bronze	

(1) Soft disc inserts available for gas or vacuum service.

FIGURE NUMBERS

Class	Figure No.
150	0074V
300	1074V
600	2074V

PRESSURE/TEMPERATURE RATINGS

Material	Temp. °F °C	Working Pressure			Shell Test Pressure		
		150	300	600	150	300	600
A 216 Gr. WCB	100	285	740	1480	450	1125	2225
	38	20	51	102			
A 351 Gr. CF8M	800	80	410	825	31	78	153
	427	5.5	28	57			
A 351 Gr. CF8M	100	275	720	1440	425	1100	2175
	38	19	50	99			
A 351 Gr. CF8M	1000	20	350	700	29	76	150
	538	1.4	24	48			

DIMENSIONS AND WEIGHTS

Size in mm	Class 150						Class 300						Class 600					
	Center to Top		End to End	Weight		Center to Top	Center to Top		End to End	Weight		Center to Top	Center to Top		End to End	Weight		
	Closed	Open		BW	FL		Closed	Open		BW	FL		Closed	Open		BW	FL	
2	14.35	14.98	8.00	50	57	14.35	14.98	10.50	54	62	17.64	18.14	11.50	81	93			
50	364	380	203	23	26	364	380	267	25	28	448	461	292	37	42			
2½	14.72	15.34	8.50	56	60	14.72	15.34	11.50	65	74	18.00	19.43	13.00	120	131			
65	374	390	216	26	27	374	390	292	30	34	457	494	330	54	59			
3	17.07	17.82	9.50	85	105	17.07	17.82	12.50	91	117	24.30	25.03	14.00	175	195			
80	433	453	241	39	48	433	453	318	41	53	617	636	356	79	88			
4	21.16	22.16	11.50	124	156	21.16	22.16	14.00	134	175	27.72	28.75	17.00	288	360			
100	537	563	292	56	71	537	563	356	61	79	704	730	432	131	163			
6	23.76	25.01	16.00	246	286	23.76	25.01	17.50	267	343	38.82	40.32	22.00	560	660			
150	604	635	406	116	130	604	635	445	121	156	986	1024	559	254	299			
8	28.85	30.46	19.50	413	443	31.98	33.59	22.00	455	573	51.56	53.56	26.00	1418	1588			
200	733	774	495	187	201	812	853	559	206	260	1310	1360	660	643	720			



FORGED STEEL BELLOWS SEAL Y-PATTERN GLOBE VALVES

½ -2" (15-50 mm) ASME CLASSES 1500, 2500

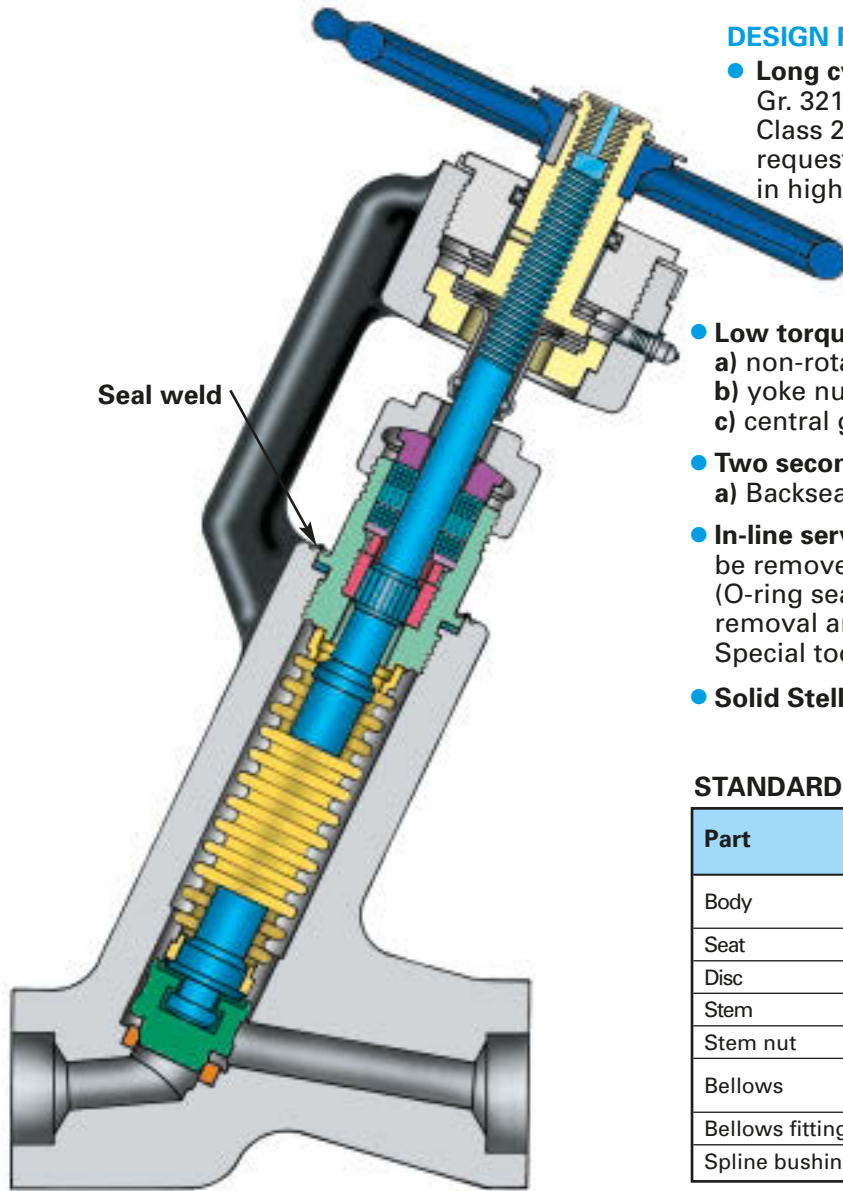

DESIGN FEATURES:

- **Long cycle life bellows (5000 cycles).**
Gr. 321 (stainless) for Class 1500, Hastelloy for Class 2500. Optional materials available on request. Designed for, and successfully tested in high pressure/temperature conditions.
- **No torsion of bellows.**
Splined stem prevents torsion of bellows and assures long cycle life.
- **Low torque due to:**
 - a) non-rotating stem
 - b) yoke nut thrust bearings
 - c) central grease fitting for lubrication of stem nut.
- **Two secondary stem seals:**
 - a) Backseat in open position
 - b) Graphite packing.
- **In-line servicing.** Stem-bellows assembly can easily be removed and replaced on valves with threaded (O-ring seat) bonnet. On seal-welded valves, removal and replacement of weld is necessary. Special tools are available for cutting the seal weld.
- **Solid Stellite disc and seat.** (Seat vacuum brazed).

STANDARD MATERIALS

Part	Carbon Steel	Alloy Steel	Stainless Steel
Body	A 105N	A 182 Gr. F22	A 182 Gr. F316
Seat	Stellite 6		
Disc	Stellite 6		
Stem	Gr. 410 (stainless)	Gr. 316B (stainless)	
Stem nut	Austenitic ductile iron A 439 Gr. D-2C		
Bellows	Class 1500 Gr. 321 (stainless) or Inconel Class 2500 Hastelloy C		
Bellows fitting	Gr. 321 (stainless)		
Spline bushing	Gr. 630 (stainless)		

DIMENSIONS AND WEIGHTS

Size in mm	End to End	Center to Top	Handwheel	Weight lb kg
½ 15	5.75 146	11.90 302	6.00 152	29 13
¾ 20	5.75 146	11.90 302	6.00 152	29 13
1 25	5.75 146	11.90 302	6.00 152	29 13
1¼ 32	10.13 257	18.90 480	12.00 305	83 38
1½ 40	10.13 257	18.90 480	12.00 305	83 38
2 50	10.13 257	18.90 480	12.00 305	83 38

PRESSURE/TEMPERATURE RATINGS

Material	Temp. °F °C	Working Pressure psig bar		Shell Test Pressure psig bar	
		1500	2500	1500	2500
A 105N	100	3705	6170	5575	9275
	38	256	426		
	800	2060	3430	384	640
A 182 Gr. F22	100	3750	6250	5625	9375
	38	259	431		
	1000	1305	2170	388	647
A 182 Gr. F316	100	3600	6000	5400	9000
	38	248	414		
	1000	1750	2915	372	621
	538	121	201		



FORGED STEEL BELLOWS SEAL BOLTED BONNET GLOBE VALVES

2½–10" (65–250 mm) ASME CLASSES 600, 900, 1500
WITH OPTIONAL PROVISION FOR SEAL WELDING

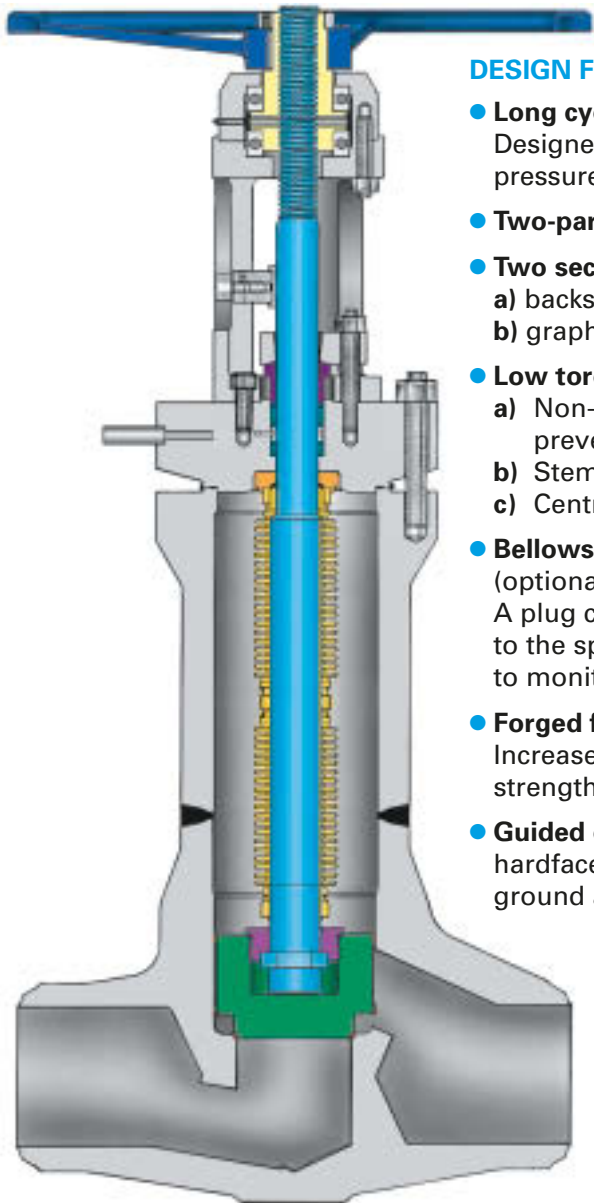

DESIGN FEATURES:

- **Long cycle life bellows (3000 cycles)** in Gr. 321 (stainless) or Inconel. Designed and successfully tested in high pressure/temperature conditions.
- **Two-part bellows.**
- **Two secondary stem seals:**
 - a) backseat in open position
 - b) graphite packing.
- **Low torque.**
 - a) Non-rotating stem prevents torsion of bellows
 - b) Stem nut thrust bearings
 - c) Central lubrication.
- **Bellows monitoring port (optional).**
A plug can be connected to the space above the bellows to monitor performance.
- **Forged for higher safety.**
Increased toughness, strength and fatigue resistance.
- **Guided disc.** Seat and disc hardfaced with Stellite 6, ground and lapped.

STANDARD MATERIALS

Part	Carbon steel	Stainless steel
Body/bonnet	A 105	A 182 Gr. F316
Stem	Gr. 13 CR	Gr. 316
Disc ⁽¹⁾	A 105 ⁽²⁾	Gr. F 316 ⁽²⁾
Bellows	Gr. 321 (stainless), Inconel or Hastelloy	
Bellows fitting	Gr. 321 (stainless)	
Packing	Graphite	
Seat	Integral Hardfaced Stellite 6	
Stem nut	Manganese bronze	

(1) Soft disc inserts available for gas or vacuum service.

(2) Hardfaced Stellite 6

FIGURE NUMBERS

Class	Figure No.
600	2074R
900	7074R
1500	3074R

PRESSURE/TEMPERATURE RATINGS

Material	Temp. °F °C	Working Pressure psig bar			Shell Test Pressure psig bar		
		600	900	1500	600	900	1500
A 105	100	1480	2220	3705	2225	3350	5575
	38	102	153	256			
	800	825	1235	2060	153	231	384
	427	57	85	142			
A 182 Gr. F316	100	1440	2160	3600	2175	3250	5400
	38	99	149	248			
	1000	700	1050	1750	150	224	372
	538	48	72	121			

DIMENSIONS AND WEIGHTS

Size in mm	Center to Top of Handwheel in mm			End to End in mm			Weight (Butt Weld) lb kg		
	600	900	1500	600	900	1500	600	900	1500
2½ 65	22 559	26 660	29 737	8.50 216	10 254	10 254	120 55	135 61	145 66
3 80	23 584	28 711	31 787	10 254	12 305	12 305	225 102	240 109	250 113
4 100	31 787	35 889	38 965	12 305	14 356	16 406	305 139	325 147	345 157
6 150	41 1041	47 1194	51 1295	22 559	20 508	22 559	790 359	880 399	925 420
8 200	44 1118	55 1270	60 1524	26 660	26 660	28 711	1350 613	1580 717	1650 748
10 250	48 1219	59 1499	65 1651	31 787	31 787	34 864	1800 817	2050 930	2175 987



TE-150/300 BELLOWS SEAL MEMORY SEAL BALL VALVES

CARBON, STAINLESS STEEL AND OTHER MATERIALS
REGULAR PORT ½–2" (15–50 mm) FULL PORT ½–1½" (15–40 mm),
SCREWED, SOCKET WELD, BUTT WELD, FLANGED, ASME Classes 150, 300



DESIGN FEATURES:

- **Hermetically sealed.**
- **Laboratory testing to 100,000 cycles** with "0" ppm emissions.
- **Long cycle life bellows** in Hastelloy C.
- **Secondary PTFE or graphite packing seal.**
- **A unique bellows seal design** with stainless steel driver unit allows installation of standard, pneumatic or electric actuator.
- **Only one fully-encased spiral wound SS 316 graphite gasket** is exposed to pressure. The gasket in the driver unit acts only in the event of bellows failure.
- **Monitoring plug.** Can determine bellows failure.
- Design permits **disassembly in-line.**
- **Unique "in-tension" seats** with induced sealing memory compensate for wear and pressure/temperature fluctuations.
- **Stainless steel trim.**
- **Fire safe** to API 607 Rev. 3, and BS 6755 (standard valves) and API 607 Rev. 4 (graphite packing).

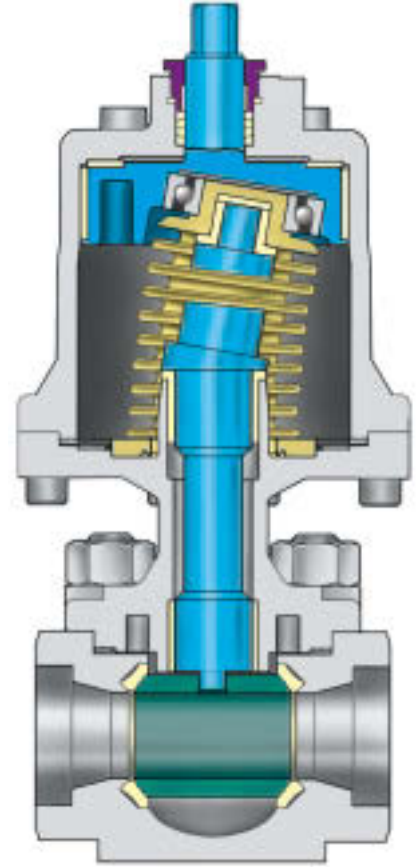

Laboratory testing for 100,000 cycles with 0 ppm.

FLOW COEFFICIENT Cv FOR ALL TE-150/300 VALVES

Size in	Regular Port	Full Port
½	8	26
¾	13.5	75
1	34	103
1½	65	206
2	104	—

NOTE:

1. For hazardous service, the customer must arrange to have a redundant ball position indicator (like a proximity switch) installed to insure safety in the event of mechanical failure of the Bellows seal unit.
2. The customer must verify that all internal components of the valve and bellows seal unit are compatible with the application fluid.

**TYPICAL MATERIALS LIST
FOR A STAINLESS STEEL VALVE**

Part	Standard Materials
Body / Bonnet	A 351 Gr. C8FM
Spindle	Gr. 316
Ball	A 351 Gr. C8FM
Seat	PTFE, RPTFE, E-PTFE, C-RPTFE
Housing	A 351 Gr. C8FM
Packing ring	PTFE
Stud	Gr. B8M Cl. 2
Nut	Gr. 8M
Housing screw	Gr. B8M Cl. 2
Bonnet seal	Gr. 316 spiral wound graphite
Housing seal	Gr. 316 graphite laminate
Garlock bearing	Steel / Bronze / PTFE
Thrust bearing	FOF 321
Ball bearing	SAE 52100
Handle nut	SS
Locking device	Gr. 304
Handle	Gr. 304
Spring	Gr. 302
Packing nut sleeve	RPTFE
Spindle sleeve	PPS
Spindle bushing	RPTFE
Bellows bushing	PPS
Packing nut	Gr. 304
NPT plug	Gr. F316
Nameplate	SS
Tag plate	SS
Driver	CF8M
Bellows assy.	C-276 / SS 316 Hastelloy

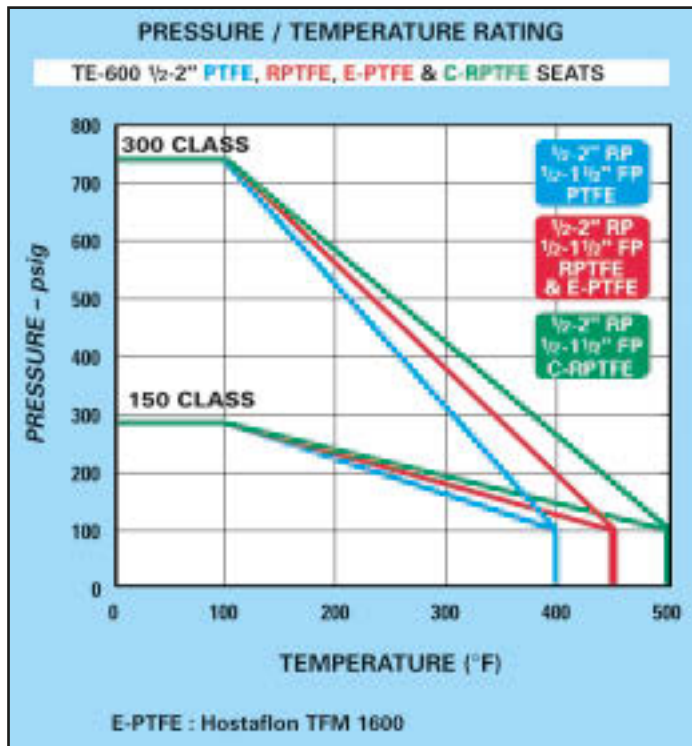

All valves available in A 105, A 182 Gr. F22 and Gr. A 315 C8FM

For other sizes, pressure classes and torque values please consult the factory.

TE-150/300 SOCKET WELD OR THREADED BELLOWS SEAL

SIZE in mm	TE-600 (REGULAR PORT) ⁽¹⁾							TOTAL WEIGHT lb kg
	A	B	C	D	E	F	G	
1/2	2.63	9.27	7.32	1.31	0.44	0.86	0.38	16
15	67	235	186	33	11	22	10	7.5
3/4	3.25	9.40	7.32	1.63	0.56	1.07	0.50	17
20	83	239	186	41	14	27	13	8
1	3.75	9.90	7.32	1.88	0.81	1.33	0.50	20
25	95	252	186	48	21	34	13	9
1 1/2	4.88	11.03	7.32	2.44	1.19	1.92	0.50	36
40	124	280	186	62	30	49	13	16
2	6.00	11.63	7.32	3.00	1.50	2.41	0.63	42
50	152	296	186	76	38	61	16	19

SIZE in mm	TE-600 (FULL PORT) ⁽¹⁾							TOTAL WEIGHT lb kg
	A	B	C	D	E	F	G	
1/2	3.25	9.40	7.32	1.63	0.56	0.86	0.38	17
15	83	239	186	41	14	22	10	8
3/4	3.75	9.90	7.32	1.88	0.81	1.07	0.50	20
20	95	252	186	48	21	27	13	9
1	4.88	11.03	7.32	2.44	1.19	1.33	0.50	37
25	124	280	186	62	30	34	13	17
1 1/2	6.00	11.63	7.32	3.00	1.50	1.92	0.50	44
40	152	296	186	76	38	49	13	20

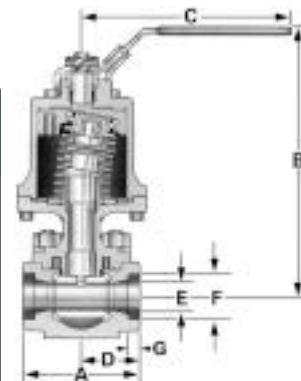

(1) For butt weld dimensions, contact the factory.

TE-150/300 FLANGED REGULAR PORT⁽¹⁾

SIZE	CLASS 150					CLASS 300			
	A		Weight		lb	kg	A		Weight
in	mm	in	mm	in			mm	lb	kg
1/2	15	4.25	108	18.4	8.3	5.50	140	19.5	8.8
3/4	20	4.63	118	20.2	9.2	6.00	152	22.4	10.2
1	25	5.00	127	23.6	10.7	6.50	165	27	12.3
1 1/2	40	6.50	165	41	18.6	7.50	191	46	20.9
2	50	7.00	178	50	22.7	8.50	216	55	25

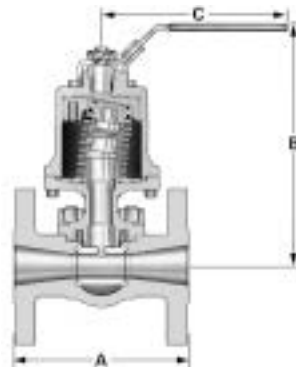

(1) For dimensions B and C, refer to table above.



BELLOWS SEAL CONTROL VALVES FOR HIGH TEMPERATURES

DESIGN FEATURES:

- No fugitive emission.
- Straight or angle body.
- Equal percentage or linear characteristic.
- Metal or soft seat.
- Low maintenance.

RANGE:

- SIZES: 1/2–6" (15–150 mm).
- Class 150 to 600.
- Cv from 0.1 to 500.
- Up to 425°C (797°F).
- Flanged or BW body

OPTIONS:

- Pneumatic actuator
- Positioner, airset
- Limit switches

APPLICATIONS:

- Hazardous fluids
- Nuclear plants
- Accurate steam control
- Pilot plants
- Laboratories
- Accurate steam control



BELLOWS SEAL CONTROL VALVES FOR CRYOGENICS

DESIGN FEATURES:

- Low thermal losses
- Exposure with liquid helium 1.4 K or -271.75°C.
- Excellent seat tightness
- Angle or Straight pattern.
- Cold box mounting
- Vacuum jacket available
- Intelligent positioners available

APPLICATIONS:







- Very low temperatures
- Liquefied Helium, Hydrogen or Oxygen.
- Rocket launching sites
- Aerospace
- Superconductivity applications.

REFERENCES

AIR-LIQUIDE, AEROSPATIALE, ALSTOM, ARIANESPACE, BOC INDIA, BP, CEA, CEGELEC, CENTRE SPATIAL DE KOUROU, CERN, CENG, CNES, COGEMA, CRYO DIFFUSION, EDF, ELF, EURODIF, FRAMATOME, GAZ DE FRANCE, GOODYEAR, ISRO, IPR, IFP, KELLOG, KODAK, LINDE, MICHELIN, OXFORD INSTRUMENTS, SONATRACH, SPIE, SGN, SOLVAY, RHONE-POULENC, TECHNIP, TOTAL, TRACTEBEL...

HOW TO ORDER BELLOWS SEAL VALVES

Velan figure numbers are designed to cover essential features. When ordering please show figure numbers to preclude misunderstanding of your requirements. A detailed description for SPECIALS must always accompany order.

Type of Connection	Size of Connection	Pressure Class	Type	Body / Bonnet Style	Body Material	Trim Material
A	B	C	D	E	F	G
						
B	1 0	- 0	0 7	4 V - 0 2	0 2	T Y

E.G.: 3" ASME Class 150 bolted bonnet bellows seal globe valve in cast carbon steel with a butt weld connection.

A TYPE OF CONNECTION

A Special **F** Flanged **W** Socket weld
B Butt weld **S** Threaded **X** Butt weld (intermediate Class)

B SIZE OF CONNECTION

03 - ½" **05** - 1" **07** - 1½" **09** - 2½" **11** - 3½" **13** - 5" **15** - 8" **18** - 12"
04 - ¾" **06** - 1¼" **08** - 2" **10** - 3" **12** - 4" **14** - 6" **16** - 10"

C CLASS

0 - 150 **2** - 600 flanged or 800 socket weld, butt weld or threaded
1 - 300 **3** - 1500 **4** - 2500 **6** - 400 **7** - 900

D VALVE TYPE

05 - Standard port gate **07** - Stop (globe) **18** - Drain
06 - Full port gate **17** - IREB

E BODY/BONNET STYLE

4 - Vertical **R** - Forged bolted bonnet bellows seal
6 - Y-pattern (inclined) **S** - Bellows seal made in Y-pattern forging
T - Bellows seal all welded design **V** - Cast bolted bonnet bellows seal

F BODY MATERIAL

01 - Special **02** - A105, WCB **06** - Chr. Moly F22, WC9
05 - Chr. Moly F11, WC6 **13** - Stainless Steel F316, CF8M **14** - Stainless Steel F316L, CF3M

G TRIM MATERIAL

PRODUCT	TRIM CODE	WEDGE / DISC SEATING SURFACE ⁽¹⁾	SEAT SURFACE ⁽¹⁾	STEM
½ - 2" Forged	TS MS	Stellite 6	Stellite 6	13% CR 316 or 630
2½ - 12" Forged	TS MS	Stellite 6	Stellite 6	13% CR 316 or 630
2 - 12" Cast	TY TS MY MS	Stellite 6 or 13 CR	Stellite 6	13% CR 13% CR SS 316 SS 316
NACE H ₂ S SERVICE	NA ⁽²⁾	13 CR (410 or CA 15)	Stellite 6	410 HRC 22 max.
	NB ⁽²⁾	Stellite or CF8M	Stellite 6	SS 316
	NC ⁽²⁾	Monel	Stellite 6	Monel or Monel K

⁽¹⁾ Base material may be same as body or same as trim at manufacturer's option.

⁽²⁾ NA, NB and NC trims are for NACE service and are supplied with bolting with maximum hardness of Rc. 22.

The most comprehensive line of industrial forged and cast steel gate, globe, check, ball, butterfly, and knife gate valves and steam traps.

ASME pressure classes 150–4500 in carbon, alloy, and stainless steel

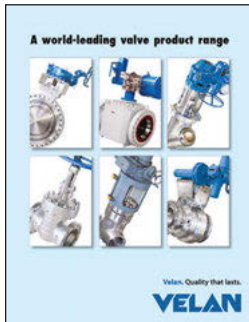

BRO-FLB

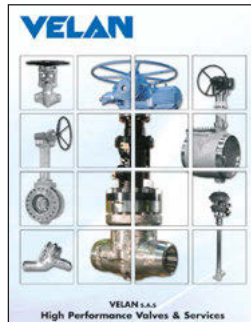

SAS-FLB

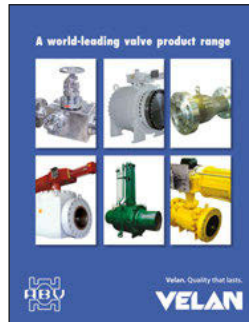

ABV-FLB

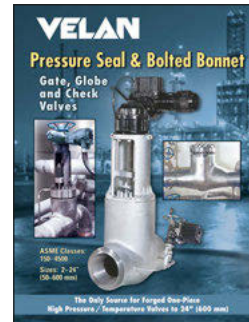

VEL-PS

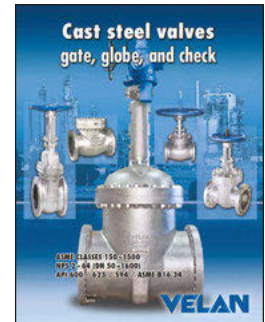

CAT-CSV

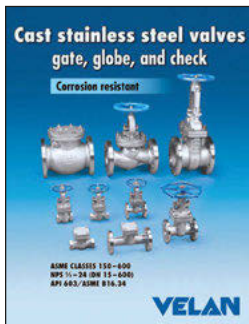

CAT-CSSV

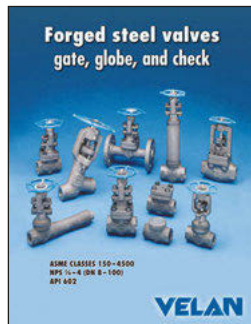

CAT-SFV

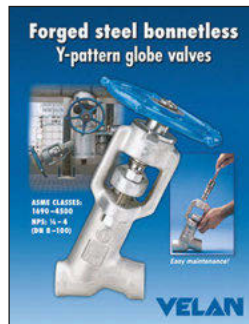

CAT-BG

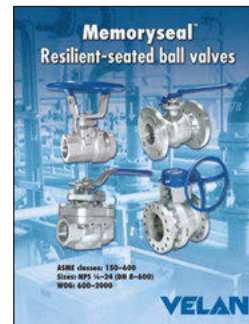

CAT-BV

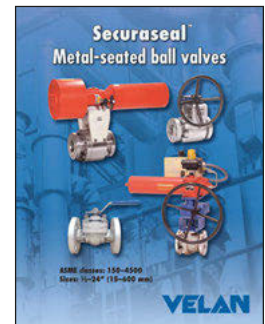

VEL-MS

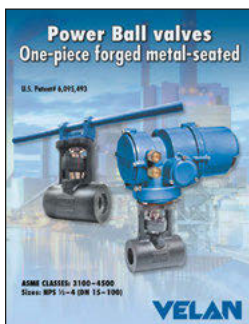

CAT-PBV

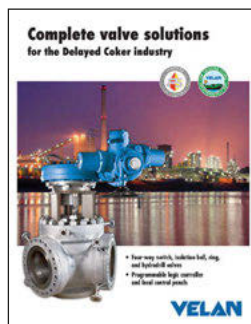

BRO-CBV

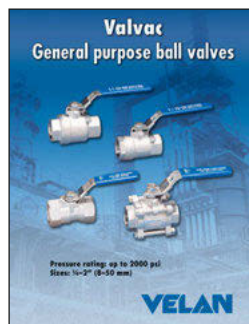

CAT-GPBV

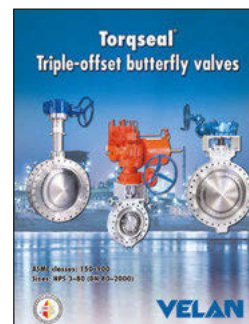

CAT-BF

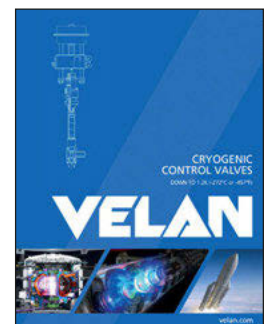

SAS-CCV

⚠ WARNING: The use of chainwheels may present a risk of serious injury to personnel or damage to property if the chainwheel becomes detached and falls. The end user and purchaser shall be responsible to ensure the correct installation, operation, maintenance and safety provisions related to chainwheels. Velan does not assume any liability whatsoever for the safe application and operation of chainwheels supplied by parties other than Velan or for chainwheels that are used without a suitably designed safety device.

Headquartered in Montreal, Canada, Velan has several international subsidiaries. For general inquiries:

Velan head office

7007 Côte de Liesse, Montreal, QC H4T 1G2 Canada

Tel: +1 514 748 7743 Fax: +1 514 748 8635

Check our website for more specific contact information.

www.velan.com

VEL-BS-2001a

Printed in Canada

© 2019 Velan Inc., Montreal, QC, Canada. All rights reserved. The contents hereof are confidential and proprietary to Velan. Any unauthorized reproduction or disclosure, in whole or in part, is strictly prohibited. The material in this catalog is for general information only and shall not be used for specific performance data and material selection without first consulting Velan. Velan reserves the right to change this information without notice. Velan does not accept any liability or damages arising from the use of information in this catalog. Velan, Velan Ultraflex, Steamless, Moss, Torqseal, Memoryseal, Securaseal, Velflex, Rama, Clama, Adareg, and Rama Clama II are trademarks or registered trademarks of Velan Inc. and/or another Velan company. One or more of these trademarks are registered in certain countries/regions, please contact Velan Inc.'s legal department for further information. All other trademarks and registered trademarks are owned by their respective companies.

